

TO ALL KNOWN CREDITORS AND MEMBERS

26 April 2024

Ref: LW/JB/AH/HW/SGPLC01/SSP01  
Email: SGPLCcomms@uk.ey.com

Dear Sir/Madam

**Saietta Sunderland Plant Limited (in Administration) (“the Company”)**

As you will be aware, the above-named Company entered Administration on 4 March 2024 and Lucy Winterborne and I were appointed to act as Joint Administrators.

I now enclose a copy of our statement of proposals as required by paragraph 49 of Schedule B1 to the Insolvency Act 1986.

We intend to seek the approval of the proposals by deemed consent. We will seek approval for the basis of our remuneration by a separate resolution of the creditors at a later date.

I enclose, for your attention, formal notice of deemed consent together with an invitation to form a creditors’ committee.

Should you have any further questions please contact Ayse Hassan at [SGPLCcomms@uk.ey.com](mailto:SGPLCcomms@uk.ey.com)

Yours faithfully  
For the Company

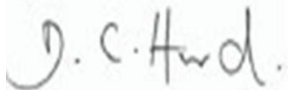

Daniel Christopher Hurd  
Joint Administrator

Enc: Administrators’ Statements of Proposals  
Notice of deemed consent  
Invitation to form a creditors committee

Lucy Winterborne is licensed in the United Kingdom to act as an insolvency practitioner by The Insolvency Practitioners Association in England and Wales. D C Hurd is licensed in the United Kingdom to act as an insolvency practitioner by The Institute of Chartered Accountants in England and Wales. As Insolvency Practitioners, they are bound by the Insolvency Code of Ethics in carrying out all professional work relating to the appointment.

The affairs, business and property of the Company is being managed by the Joint Administrators, L Winterborne and D C Hurd, who act as agents of the Company only and without personal liability.

The Joint Administrators may act as data controllers of personal data as defined by the UK General Data Protection Regulation (as incorporated in the Data Protection Act 2018), depending upon the specific processing activities undertaken. Ernst & Young LLP and/or the Companies may act as a data processor on the instructions of the Joint Administrators. Personal data will be kept secure and processed only for matters relating to the Joint Administrator’s appointment. The Office Holder Data Privacy Notice can be found at [www.ey.com/uk/officeholderprivacy](http://www.ey.com/uk/officeholderprivacy).

**Saietta Group Plc and Saietta Sunderland  
Plant Limited (both in Administration)  
("the Companies")**

Administrators' statement of proposals

Pursuant to paragraph 49 of schedule B1 to the  
Insolvency Act 1986 (England and Wales)

Date of delivery of proposals to creditors 26 April 2024

## Abbreviations

The following abbreviations are used in this report:

<b>The Act</b>	The Insolvency Act 1986
<b>Aon</b>	Aon UK Limited
<b>CDDA</b>	Company Directors Disqualification Act 1986
<b>CIM</b>	Confidential Information Memorandum
<b>the Companies</b>	Saietta Group Plc and Saietta Sunderland Plant Limited (both in Administration) (“the Companies”)
<b>Date of appointment</b>	4 March 2024
<b>Directors</b>	<p><b>SGP:</b>            Seshu Bhagavathula            Emmanuel Dominique Clair            Anthony David Gott            Devyani Vaishampayan            David Wilkinson            David John Woolley</p> <p><b>SSP:</b>            Anthony David Gott</p>
<b>EY</b>	Ernst & Young LLP
<b>HMRC</b>	HM Revenue and Customs
<b>Hilco</b>	Hilco Appraisal Limited
<b>the Joint Administrators or the Administrators</b>	Lucy Winterborne and Daniel Christopher Hurd
<b>LTO</b>	License to Occupy
<b>Management</b>	Management of Saietta Group Plc and/or Saietta Sunderland Plant Limited (both in Administration)
<b>NBO</b>	Non-Binding Offer
<b>The Proposals</b>	The Joint Administrators’ Statement of Proposals
<b>The Purchaser</b>	Exedy Clutch Europe Limited
<b>RPS</b>	The Redundancy Payments Service
<b>The Rules</b>	The Insolvency (England & Wales) Rules 2016
<b>SGP</b>	Saietta Group Plc
<b>SSP</b>	Saietta Sunderland Plant Limited

<b>SVNA</b>	Saietta VNA Private Ltd (registered in India)
<b>TTP</b>	Time to Pay arrangement
<b>TUPE</b>	Transfer of Undertakings (Protection of Employment) Regulations 2006
<b>VAT</b>	Value Added Tax

## Contents

1. Introduction, background and circumstances giving rise to the appointment .....	2
2. Purpose, conduct and end of administration.....	7
3. Statement of Affairs .....	14
4. Prescribed part.....	16
5. Administrators' remuneration and disbursements and payments to other professionals .....	17
6. Pre administration costs .....	19
Appendix A Statutory information.....	21
Appendix B Directors' statement of affairs .....	23
Appendix C Administrators' receipts and payments account for the period from 4 March 2024 to 25 April 2024 .....	55
Appendix D Statement of pre-administration costs .....	57

# 1. Introduction, background and circumstances giving rise to the appointment

## Introduction

On 4 March 2024 the Companies entered Administration and Lucy Winterborne and Daniel Christopher Hurd were appointed to act as Joint Administrators (“the Joint Administrators”). The appointment was made by the Companies’ directors under the provisions of paragraph 22(2) of Schedule B1 to the Insolvency Act 1986.

This document, including its appendices, constitutes the Joint Administrators’ statement of proposals to creditors pursuant to paragraph 49 of Schedule B1 to the Insolvency Act 1986 and Rule 3.35 of the Insolvency (England and Wales) Rules 2016. Certain statutory information relating to the Companies and the appointment of the Joint Administrators is provided at Appendix A.

## Background – Group structure

SGP was initially incorporated under the name Agility Racing Limited in 2008. In 2011, it changed its name to Agility Global Limited and in 2015, its name was changed again to Saietta Group Limited. In July 2021, SGP was listed on the AIM market.

SSP is a wholly owned subsidiary of SGP and was incorporated on 10 November 2008. It was previously called Agility Motors Limited until June 2012, then Saietta Motorcycles Limited until its name was changed to Saietta Sunderland Plant Limited in October 2022.

SGP owns six other subsidiaries, as shown in the group structure chart below (together, “the Group”).

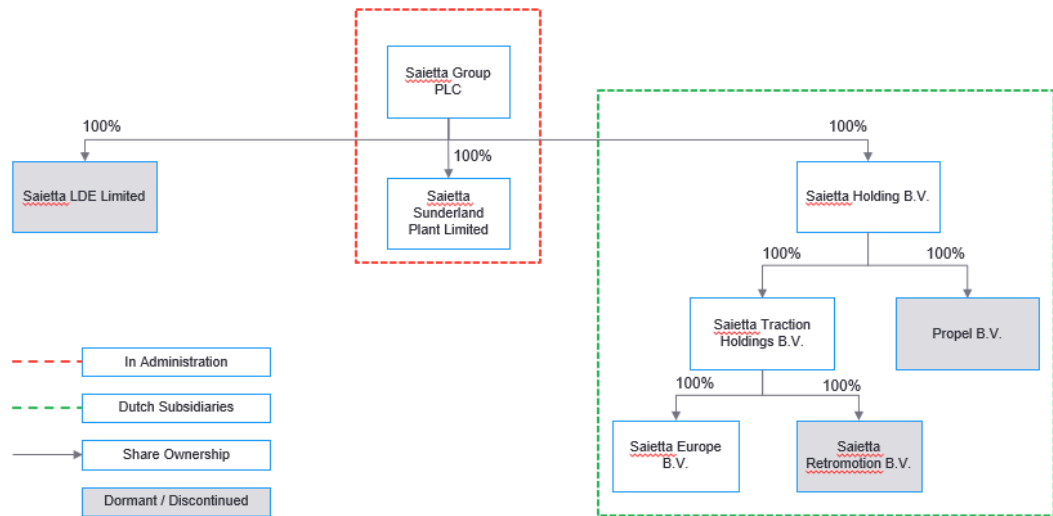

SGP also owns 49% of the shares in a joint venture located in India called Saietta VNA Private Ltd (“SVNA”). SVNA continues to trade under its own management in India.

## Background – Trading activities

SGP’s primary activity was the research, development and design of complete powertrains for electric vehicles, which included scooters and tuk-tuks. As a result, it held the majority of the Group’s intellectual property rights. It was historically the Group’s main trading entity and consequently owned the majority of the Group’s plant and machinery, as well as prototype vehicles and work in progress relating to powertrains.

The Companies traded from three locations and SGP held the leases at each of these:

- Unit 1500A, Silverstone Park, Silverstone, Northamptonshire, NN12 8FU (“Silverstone”);
- Buildings 211, 3033, Heyford Park, Upper Heyford, Bicester, Oxfordshire, OX25 5HD (“Upper Heyford”). Building 209 was also leased and sub-let to a tenant as discussed further below; and
- Unit 9 Mercantile Road, Rainton Bridge Industrial Estate, Houghton-le-Spring Sunderland, Tyne and Wear (“Sunderland”).

Just prior to the Administration, SGP employed 54 staff who were mainly based at Silverstone (the Companies’ head office). Its finance function was based in Upper Heyford.

While SSP was originally incorporated in 2008, it had been dormant for a period and was more recently renamed and repurposed to undertake the manufacture and supply of electric motors to customers. At the date of appointment it employed 33 staff at the manufacturing facility in Sunderland.

The Dutch subsidiaries specialised in developing intellectual property and technology for marine applications and heavy transport, such as buses. Prior to the appointment of the Joint Administrators these subsidiaries had largely been wound down and were not trading.

### Background - Financial information

The Companies’ financial results are summarised as follows:

#### SGP Consolidated

Period year or period ended	Type audited /draft	Turnover £000	Gross profit £000	Gross profit %	Directors’ remuneration* £000	Net loss after tax** £000	Accumulated losses £000
31 Mar ‘23	Audited	2,103	653	31.0	2,478	(19,938)	(41,946)
31 Mar ‘22	Audited	1,383	796	57.6	2,601	(10,708)	(14,140)
31 Mar ‘21	Audited	871	681	78.2	394	(6,993)	(3,458)

*The figures in the table above are consolidated, so account for the elimination of inter-company transactions.*

*\*Directors’ remuneration amounts exclude unexercised share options*

*\*\* Excluding discontinued operations and FX gains/losses*

The recent financial performance according to the management accounts of the Group can be summarised as follows:

Currency £000	9mths to Dec-23
Revenue	1,489
Cost of sales	(1,361)
Gross profit / (loss)	<u>128</u>
Other income	187
Administrative expenses	(12,646)
Finance income	9
Finance expenses	(207)
Share of results of associate	(1)
Other gains and losses	1,345
Tax credit	223
Loss for the period from continuing operations	<u>(10,963)</u>

*The above tables feature consolidated trading results and therefore include the financial performance of SGP's subsidiaries and eliminate inter-company transactions.*

### SGP standalone

The recent financial performance based on management information (trial balance) can be summarised as follows:

Currency £000	9mths to Dec-23*
Revenue	1,582
Cost of sales	(1,527)
Gross profit / (loss)	<u>55</u>
Other income	1,822
Administrative expenses	(11,823)
Finance income	31
Finance expenses	(189)
Share of results of associate	-
Other gains and losses	(457)
Tax credit	223
Loss for the period	<u>(10,338)</u>

\*Figures in the table above are shown before consolidation adjustments are applied, so include some inter-company transactions (including inter-company sales) that are eliminated on consolidation.

### SSP standalone

Period year or period ended	Type audited/ draft	Turnover £000	Gross profit £000	Gross profit %	Director's remuneration £000	Net loss after tax £000	Accumulated losses £000
31 Mar '23	Unaudited	337	(314)	(93.3)	nil	(1,356)	(1,356)



The recent financial performance according to management information (trial balance) can be summarised as follows:

Currency £000	9mths to Dec-23*
Revenue	699
Cost of sales	(694)
Gross profit / (loss)	<u>5</u>
Administrative expenses	(1,519)
Loss for the period	<u>(1,514)</u>

*\*Figures in the table above are shown before consolidation adjustments are applied, so may include some inter-company transactions that are eliminated on consolidation.*

### **Circumstances Giving Rise to the Appointment of the Joint Administrators**

Since SGP's initial admission to trade on AIM in July 2021, it had diversified from a largely research and development ("R&D") company focused on highly efficient electric motors, to a Group that developed full eDrive systems. During this period it established a manufacturing facility in Sunderland and also invested in the SVNA joint venture to focus on supply to the Indian market. SGP had also recently commenced production for a customer and was in the process of engineering bespoke solutions for other OEMs, with a view to securing future orders with them.

While the Group was expecting to benefit from these investments in R&D and diversification through future revenues, further funding was still required to fund losses during the period in which it scaled up and was forecast to become financially viable. On 19 October 2023, as part of its full year results and operational update to the market, SGP announced that it only had sufficient working capital funding to support operations to December 2023 and would be proactively engaging with stakeholders to explore financing opportunities, including raising equity.

EY was initially engaged by SGP on 13 November 2023 to assess the financial position and future prospects of the Companies, particularly with regard to liquidity concerns pending its proposed equity raise.

On 27 November 2023 SGP announced that it was launching an equity fundraise, which ultimately secured £6.5m, a significant proportion of which was to provide working capital and to reduce creditors arrears. This funding was expected to provide sufficient headroom for the Group to trade through to the end of March 2024 on the assumption that certain customer orders would be secured during that time. A further fund-raising exercise was expected to be launched after these new customer contracts were secured.

On 13 February 2024 SGP announced that an anticipated contract with a key customer had not been secured. In addition, the start dates for other anticipated customer contracts were materially postponed, putting further pressure on the Group's liquidity forecasts.

Management considered that there was still sufficient working capital to enable the Group to trade through to the end of March 2024 while SGP sought additional funding, however Management further considered there to be a material uncertainty around the Companies' ability to secure the additional funding required.

On 13 February 2024, largely due to the above factors, EY's scope of work was extended to explore an accelerated sales process, with the aim of securing a solvent sale of the Group's business. In parallel EY were also requested to commence a level of contingency planning to prepare for a potential insolvency in the event that the sale process was not successful.

Initially a discreet marketing process was commenced, limited to six parties, following guidance in respect of the AIM rules. However, by 22 February 2024, with no immediate proceedable

interest from the initial process, the Directors of SGP decided to open the process to the wider market and a regulatory news service announcement (“RNS”) was issued stating that the Group was undertaking a formal review of its strategic options, as without further funding the Group was at risk of becoming insolvent.

Following the RNS, EY approached more than 70 parties to gauge their interest in the opportunity to acquire the Group’s business. However, by 3 March 2024 there were still no proceedable offers.

In the meantime, EY’s contingency planning work had prepared for potential insolvency appointments over the Companies in the event that a solvent transaction for the sale of the Companies was not achieved. With creditor pressure increasing, liquidity decreasing and no proceedable solvent offers received, the Board decided that it had no option for SGP and SSP other than to seek the protection of Administration.

As a result, the Companies’ directors resolved to appoint Lucy Winterborne and Daniel Christopher Hurd as Joint Administrators of the Companies on 4 March 2024, under the provisions of paragraph 22(2) of Schedule B1 to the Insolvency Act 1986.

#### **Pre-Administration costs**

As a result of the work undertaken by EY described above, pre-Administration costs have been incurred by the Joint Administrators prior to the Companies entering Administration.

Please refer to Section 6 of these Proposals for further details.

## 2. Purpose, conduct and end of administration

### **Purpose of the administration**

The purpose of an administration is to achieve one of three objectives:

- a. To rescue the company as a going concern
- b. To achieve a better result for the company's creditors as a whole than would be likely if the company were wound up (without first being in administration)
- c. To realise property in order to make a distribution to one or more secured or preferential creditors

Insolvency legislation provides that objective (a) should be pursued unless it is not reasonably practicable to do so or if objective (b) would achieve a better result for the company's creditors as a whole. Objective (c) may only be pursued if it is not reasonably practicable to achieve either objective (a) or (b) and can be pursued without unnecessarily harming the interests of the creditors of the company as a whole.

Given the extensive marketing process undertaken prior to appointment with no viable going concern offers received, it was considered that objective (a) could not be achieved.

As a result, the Joint Administrators have pursued objective (b) in respect of SGP and SSP.

In this case, the protection of the moratorium gave the Companies protection from creditor action and provided the Joint Administrators time to realise value from the Companies' assets in order to maximise returns to creditors.

If the above ultimately proves to be unachievable, the Joint Administrators would seek to pursue objective (c), realising assets in order to make a distribution to the secured (we note there is only one fixed charge, registered by NatWest, against any outstanding balance on the Company's credit card and as at the date of Administration the credit card balance was zero) and preferential creditors.

### **Conduct of the administration**

#### **Initial steps**

Given the Companies' limited customer orders, lead times on necessary supplies and lack of funding, it would not have been possible to trade the Companies' business in Administration.

Following the Joint Administrators' appointment, the Companies ceased to trade on 4 March 2024. Unfortunately, as a result of the cessation of trading, 42 employees of SGP and 28 employees of SSP were made redundant immediately on appointment. A total of 17 employees across SGP and SSP were retained to assist the Joint Administrators with an orderly wind-down of the Companies' business, bringing the accounts up to date, and assisting with the process of realising the Companies' business and assets.

At the same time steps were taken to insure (Aon was engaged as the Joint Administrators' insurance broker), secure and safeguard the Companies' assets while the possibility of securing a potential buyer for the Companies' business and assets was explored further. In parallel, Hilco Appraisal Limited, was engaged to assist with exploring the options to sell the Companies' assets on a break-up basis, in the event a sale of the Companies' business and assets on a combined basis as a going concern was not achieved.

We set out below the key activities that have been pursued by the Joint Administrators following their appointments in more detail.

### **Sale of business and assets**

Following their appointment, the Joint Administrators pursued a sale of the Companies' business and/or assets, which involved liaising with both existing and new interested parties. Over the course of the whole sales process (both pre and post-Administration), over 200 potential interested parties were contacted about the opportunity, including parties identified by both Management and EY, as well as inbound enquiries following the announcement of the sales process and Administration. Of these parties, 71 requested non-disclosure agreements, with 24 parties signing.

Each of these 24 parties were provided with (i) an information memorandum (ii) a Process Letter, which set out the deadlines and requirements to support offers; and (iii) access to a virtual data room to enable preliminary due diligence. The initial deadline for non-binding offers was 14 March 2024. We received six non-binding offers. A deadline for best and final offers was set for 21 March 2024, on which date we received two final offers.

The Joint Administrators evaluated both offers, as well as an alternative scenario of selling the assets by auction, and then accepted the offer for the business and certain assets which represented the best outcome for creditors. On 28 March 2024 the business and certain assets of SGP (and any residual rights SSP might have in those assets) were sold to Exedy Clutch Europe Limited ("the Purchaser") for £2.46m (see schedule below).

In determining that this sale provided best value to the creditors of the Companies, the Joint Administrators considered the alternative options available. No viable solvent offers had been received and the ex-situ, break-up sale value of the Companies' plant and machinery assets was significantly lower after accounting for holding costs. In addition, a piecemeal disposal of the Companies' assets would likely have made it more challenging to realise value for the Companies' intellectual property.

Ultimately the consideration offered for the plant and machinery included in the offer for the business and assets was equivalent to the potential value of the Companies' plant and machinery assets if they were marketed for sale over a 180-day period before holding costs, with the additional benefit that a further c.£850k was offered for the intellectual property.

In addition, as a result of the sale, the remaining SGP employees transferred to the Purchaser under TUPE regulations, reducing the level of preferential and unsecured claims in the SGP Administration.

As part of the sale a licence to occupy ("LTO") was granted to the Purchaser over SGP's leasehold premises at Silverstone. Of the remaining 5 SSP employees, 3 have left the Company and 2 remain and are assisting the Joint Administrators with the orderly wind down of the business.

Please see below the allocation of the sale proceeds across the Companies' assets:

<b>SGP</b>	<b>£</b>
Business records	1
Goodwill	1
Intellectual property	847,297
Intellectual property licenses	1
Motor vehicles	1
Plant and machinery	1,612,690
Stock	1
<b>Total</b>	<b>2,459,992</b>

<b>SSP</b>	<b>£</b>
Business records	1
Goodwill	1
Intellectual property	1
Intellectual property licenses	1
Motor vehicles	1
Plant and machinery	1
Sunderland Assets	1
Stock	1
<b>Total</b>	<b>8</b>

Stock and certain plant and machinery located at SGP's Sunderland site was excluded from the above sale. As were debtors and other assets as detailed below.

### **Significant assets not included in the sale of business and assets**

#### **SGP**

##### **Cash at bank**

At the commencement of the Administration, there was cash at bank of £856k. This amount has been transferred into the Administration bank account as indicated in the receipts and payments accounts at Appendix C.

##### **Plant and machinery**

As noted above, there is residual plant and machinery that was not included in the sale of business. We have received offers from two parties for certain plant and machinery and expect a sale to complete imminently, which we will provide more details on in our next report. Any remaining plant and machinery is being offered at auction and this process is being managed by the Joint Administrators' chattel agents, Hilco. The auction is live at the date of this report and closes on 29 April 2024.

## **Stock**

Whilst manufacturing ceased upon Administration, certain completed orders were identified and sold for £23k on an ex-situ basis to the customer for whom the order was originally intended. The offers for the plant and machinery noted above also include consideration for stock located in Sunderland, which was not included in the sale to the Purchaser.

## **Debtors (including inter-company)**

Debtors totalled c.£1.2m at appointment, of which c.£854k relates to amounts due from SGP's joint venture SVNA, c.£120k relates to amounts due to SGP from SPPL and c.£60k relates to unpaid rent from the subtenant of unit 209 Upper Heyford. We continue to assess the collectability of these debtors and any legitimate set offs that would reduce the balances due. We will pursue outstanding debts where we believe it is commercially viable to do so.

To date c.£63k of these debts have been realised as shown in the receipts and payments account at Appendix C.

Given none of SGP's subsidiaries are currently trading and also have limited assets, it is considered unlikely that there will be any realisations from inter-company debtors. However, we are still investigating the position with the Dutch subsidiaries (see below).

## **Dutch subsidiaries**

None of the Dutch subsidiaries are currently trading and there are no retained employees. There is some intellectual property owned by one of the subsidiaries, and also stock and cash balances. However, there would be a cost associated with realising these assets, which might outweigh the benefit to creditors. We are in the process of investigating the commercial viability of realising value from these subsidiaries for the benefit of the Company's creditors.

## **Joint Venture holding**

As previously mentioned, SGP is a 49% shareholder of a joint venture located in India which continues to trade under its own management. Work is ongoing to investigate whether there could be realisable value in the shares.

## **SSP**

### **Plant and machinery**

As at 31 December 2023 SSP had plant and machinery with a net book value of c.£90k. However, due to the nature of the assets we believe the net realisable value from these assets to be minimal.

### **Cash at bank**

At the commencement of the Administration, there was cash at bank of £324k. This amount has been transferred into the Administration bank account as indicated in the receipts and payments accounts at Appendix C.

### **VAT refund**

According to the Directors' Statement of Affairs, SSP is due a refund of £118k from HMRC in relation to pre-appointment VAT.

However, HMRC may be entitled to set off this debt against any unpaid direct and indirect taxes so whilst various tax returns are being brought up to date, it is not clear at this stage how much may be realised in respect of this balance.

## **Suppliers - SGP**

The Joint Administrators have been working with various suppliers throughout the Administration process, this work includes:

### ***Third party assets***

A number of suppliers have identified and collected items of plant and equipment which were subject to rental or lease agreements. The Joint Administrators and their staff have been assisting with the collection of these assets.

### ***Leased motor vehicles***

SGP had a motor fleet of 17 vehicles with Lease Plan UK Limited ("Lease Plan"). We understand that Lease Plan have collected 6 vehicles to date. There was no equity in these vehicles.

### ***Retention of title claims***

Since the date of appointment, the Company has been notified of two potential retention of title claims. One of these claims has been concluded following the collection of the goods title was claimed over. We are currently progressing work to assess the remaining retention of title claim.

### ***IT***

Due to the nature of the Companies' business and assets (a key asset being intellectual property) the Joint Administrators have worked closely with the Companies' pre-Administration IT suppliers to ensure data, books and records were secured and persevered.

This work has included capturing data from various sources, including Microsoft platforms, servers, accounting systems and various other software used by the Companies.

## **Leasehold properties**

### ***Silverstone***

Upon the completion of the sale of business and certain assets on 28 March 2024, a LTO in respect of Silverstone was granted to the Purchaser to provide time for the business to re-establish immediately upon the sale.

### ***Upper Heyford***

The property was vacated on 15 April 2024 and the Joint Administrators have offered the landlord a surrender of the leases and we understand that the landlord will liaise with the sub-tenant in relation to its tenancy at Unit 209 Upper Heyford.

### ***Sunderland***

The Companies for the time being are occupying the property to facilitate the sale(s) of remaining plant and machinery not included with the initial sale of business to the Purchaser.

## **Joint Administrators' receipts and payments**

A summary of the Joint Administrators' receipts and payments for the period from 4 March 2024 to 25 April 2024 is attached at Appendix C.

### **Approval of the Joint Administrators' proposals**

The Joint Administrators are seeking approval of their Proposals by deemed consent. Further details of the arrangements and any steps to be taken by creditors are given in the formal notice of deemed consent delivered to creditors with these Proposals.

### **Future conduct of the Administration**

The Joint Administrators will continue to deal with the Administrations of the Companies in line with the stated objective, namely to achieve a better result for the Companies' creditors as a whole than would be likely if the Companies were wound up (without first being in Administration).

Future tasks will include, but may not be limited to, the following:

- Collecting debtor balances due to the Companies;
- Investigating and taking steps to recover any outstanding balances due from related entities where commercially viable and in the interests of the Companies creditors;
- Taking all such steps as the Joint Administrators deem appropriate to realise value from the Companies' remaining assets;
- Distributing amounts to primary preferential and secondary preferential creditors (as applicable);
- Review, adjudicate and settle Retention of Title ("RoT") claims;
- Dealing with the SGP's leasehold properties and obligations under the LTO;
- Exploring the options available to realise value from the Dutch subsidiaries, if possible.
- Dealing with unsecured creditor queries;
- Reviewing and adjudicating unsecured creditor claims (as applicable);
- Assisting redundant employees with any claims against the Redundancy Payments Office and/or the Companies (as applicable);
- Dealing with corporation tax and VAT matters, which includes filling statutory returns;
- Carrying out investigative procedures, including investigating the conduct of the Company's directors leading up to the Joint Administrators' appointment in accordance with the requirements of the CDDA;
- Ensuring all statutory reporting and compliance obligations are met;
- Finalising the Administrations including payment of all Administration liabilities;
- If the Joint Administrators deem it appropriate, to seek an extension and/or further extensions to the Administrations from the Companies' creditors and/or the Court; and
- Any other actions required to be undertaken by the Joint Administrators in order to fulfil the purpose of the Administrations.

### **The end of the Administration - SGP**

As we currently anticipate that there will be a distribution to the non-preferential creditors of SGP, it is proposed that, at the end of the Administration, SGP will move straight into Creditors Voluntary Liquidation ("CVL") upon the filing with the Registrar of Companies of a notice



pursuant to paragraph 83 of Schedule B1 to the Insolvency Act 1986. It is proposed that the liquidators will be Lucy Winterborne and Daniel Christopher Hurd of Ernst & Young LLP and that any act required or authorised under any enactment to be done by the liquidators may be done by either or both of them.

In accordance with paragraph 83(7) of Schedule B1 to the Insolvency Act 1986 and Rule 3.60(6)(b) of the Insolvency (England and Wales) Rules 2016, creditors may nominate a different person as the proposed liquidator, provided that the nomination is made after the receipt of these proposals and before the proposals are approved. It should be noted in this regard that a person must be authorised to act as an insolvency practitioner in order to be appointed as liquidator.

However, if at the end of the SGP Administration, the Company has no property which might permit a distribution to its non-preferential, unsecured creditors, the Joint Administrators will send a notice to that effect to the Registrar of Companies. On registration of the notice, the Joint Administrators' appointment in respect of SGP will come to an end. In accordance with the provisions of paragraph 84(6) of Schedule B1 to the Insolvency Act 1986, the Company will be deemed to be dissolved three months after the registration of the notice.

#### **The end of the Administration - SSP**

It is currently uncertain whether there will be sufficient funds at the end of the SSP Administration to make a distribution to its non-preferential, unsecured creditors.

If there are sufficient funds then it is proposed that, at the end of the Administration, SSP will move straight into CVL upon the filing with the Registrar of Companies of a notice pursuant to paragraph 83 of Schedule B1 to the Insolvency Act 1986. It is proposed that the liquidators will be Lucy Winterborne and Daniel Christopher Hurd of Ernst & Young LLP and that any act required or authorised under any enactment to be done by the liquidators may be done by either or both of them.

In accordance with paragraph 83(7) of Schedule B1 to the Insolvency Act 1986 and Rule 3.60(6)(b) of the Insolvency (England and Wales) Rules 2016, creditors may nominate a different person as the proposed liquidator, provided that the nomination is made after the receipt of these proposals and before the proposals are approved. It should be noted in this regard that a person must be authorised to act as an insolvency practitioner in order to be appointed as liquidator.

If there are not sufficient funds at the end of the SSP Administration to make a distribution to its non-preferential, unsecured creditors, the Joint Administrators will send a notice to that effect to the Registrar of Companies. On registration of the notice, the Joint Administrators' appointment in respect of SSP will come to an end. In accordance with the provisions of paragraph 84(6) of Schedule B1 to the Insolvency Act 1986, the Company will be deemed to be dissolved three months after the registration of the notice.

### 3. Statement of Affairs

The Directors have submitted their Statement of Affairs (“SoA”) as at 4 March 2024 for SGP and SSP. Summaries are attached at Appendix B, including a full list of creditors for both Companies.

We would comment that a number of the asset values have yet to be determined and may be lower than indicated. Similarly, a number of creditor claims have yet to be quantified and may be higher than indicated. Additionally, the values are shown before applicable costs of realisation.

We provide below an indication of the current position with regard to Companies’ creditors’ claims based on the information provided in the SoA:

#### **Secured creditors**

NatWest have a fixed charge over SGP’s deposit account to the value of any outstanding balance in respect of SGP’s corporate credit card (up to a limit of £20k). As at the date of the administration we understand that the corporate credit card balance was zero.

There are no other charges and there is no qualifying floating charge holder. Accordingly, we believe there are no secured creditor claims.

#### **Preferential creditors**

##### ***Primary preferential creditors***

Claims from employees in respect of accrued but unpaid arrears of pay up to £800, accrued but unpaid holiday pay and certain pension benefits, rank preferentially and in priority to other preferential creditors (see below). These claims are therefore referred to as ‘primary preferential creditors’.

The amount of primary preferential creditors as at the date of the appointment is estimated to be c.£49.7k in SGP and c.£15.7k SSP. This balance includes a claim from the Redundancy Payments Service (“RPS”) where redundant employees have lodged relevant claims to the RPS following the end of their employment.

Based on current estimates, we anticipate that primary preferential creditors will be paid in full in both SGP and SSP Administrations. However, we are awaiting the submission of final primary preferential claims. The Joint Administrators will provide an update on the timing of any dividends in their first six monthly progress report.

##### ***Secondary preferential creditors***

Claims from HMRC, in relation to VAT, PAYE and employees’ National Insurance Contributions rank preferentially, but secondary to the employee primary preferential creditors above. These claims are therefore referred to as ‘secondary preferential creditors’.

SGP agreed a TTP arrangement with HMRC in relation to unpaid PAYE relating to the periods ending 5 October and 5 November 2023 totalling c£356k. Payments were due to commence on 12 December 2023 and we understand that 3 payments of c£71k were paid under this arrangement in addition to an upfront payment of c£80k, therefore the balance remaining in respect of the TTP is c£63k.

Based on the TTP arrears and information contained in the Director’s Statement of Affairs for SGP and SSP, we estimate the amount of secondary preferential claims at the date of our appointment to be c.£127.7k in SGP and c.£9.9k in SSP.

Based on current estimates, we anticipate that secondary preferential creditors will receive a dividend in both SGP and SSP Administrations. The quantum and timing of any dividend payment is dependent on future asset realisations and submission of final secondary preferential claims. The Joint Administrators will provide an update in their first six monthly process report.

### **Non-preferential creditors**

Non-preferential unsecured creditors are estimated to be in the region of c.£4,748k for SGP and c.£3,206k for SSP. The final figure for total non-preferential creditor claims will not be known until all claims have been received and adjudicated and it is possible that this figure may be higher or lower than this.

The Joint Administrators continue to receive claims from non-preferential unsecured creditors.

On current estimates we anticipate that there will be sufficient funds to enable a dividend to non-preferential creditors of SGP. The quantum and timing of any dividend payment is dependent on future asset realisations.

It is currently uncertain whether there will be sufficient funds to enable a dividend to non-preferential creditors of SSP. If there were to be funds available, the Joint Administrators currently believe any dividend would be nominal.

We will provide an update on the expected non-preferential creditor position in the Joint Administrators' first six monthly progress report to creditors.

## 4. Prescribed part

The prescribed part is a proportion of floating charge assets set aside for unsecured creditors pursuant to section 176A of the Insolvency Act 1986. The prescribed part applies to floating charges created on or after 15 September 2003.

As noted above, there are no floating charges registered against either of the Companies.

Consequently, section 176A of the Insolvency Act 1986 does not apply to either Administration and there is no prescribed part to be set aside for unsecured creditors.

## 5. Administrators' remuneration and disbursements and payments to other professionals

### Remuneration

The statutory provisions relating to remuneration are set out in Chapter 4, Part 18 of the Insolvency (England and Wales) Rules 2016. Further information is given in the Association of Business Recovery Professionals' publication 'A Creditors' Guide to Administrators' Fees', a copy of which may be accessed from the web site of the Institute of Chartered Accountants in England and Wales at <https://www.icaew.com/en/technical/insolvency/creditors-guides> or is available in hard copy upon written request to the Joint Administrators.

The Joint Administrators propose that their remuneration is fixed on the basis of time properly given by them and their staff in dealing with matters arising in the Administration. In the event that a creditor's committee is not formed, the Joint Administrators will seek approval for the basis of their remuneration by a decision of the creditors. Accordingly, a fee estimate and statement of expenses will be circulated under separate correspondence in due course.

Up to the 12 April 2024, the Joint Administrators have incurred time costs of £642,484 in SGP and £70,663 in SSP in relation to time properly spent undertaking statutory duties.

### Disbursements

Disbursements are expenses met by and reimbursed to the Joint Administrators. They fall into two categories: Category 1 and Category 2. When the Administrators provide their fee estimate, this will include details of the Category 1 and 2 disbursements which are expected to be incurred.

Category 1 disbursements are payments to independent third parties where there is expenditure directly referable to the administration. Category 1 disbursements can be drawn without prior approval.

Category 2 disbursements are expenses that are directly referable to the administration but not to a payment to an independent third party. They may include an element of shared or allocated costs that can be allocated to the appointment on a proper and reasonable basis. Category 2 disbursements require approval in the same manner as remuneration. In the event that a creditors' committee is not formed, the Joint Administrators will propose that they are permitted to charge Category 2 disbursements in accordance with the statement of expenses that will be circulated under separate correspondence to all creditors in due course.

### Payments to other professionals

The Joint Administrators have engaged the following other professionals to assist them. They were chosen on the basis of their experience in similar assignments and/or their specialist knowledge of the market.

Name of service provider	Description of services	Reasons for choosing the service provider
FF LLP ("FF")	Legal services	FF were involved with the Company prior to EY's involvement as its legal advisor and were engaged during the sale process (SPA) and therefore had prior knowledge of the legal affairs and business.
AON UK Limited ("AON")	Insurance	The Joint Administrators and EY in general have used AON on multiple previous insolvency appointments and therefore have a well-established relationship and

		<p>are aware of the quality of their work and reliability of their agents.</p> <p>Their fees are also reasonable and in line with expectations.</p>
Hilco Appraisal Limited ("Hilco")	Asset valuation	<p>Hilco had previously been involved in valuing certain of the Company's assets on a prior transaction and therefore had some prior knowledge. In addition, the Joint Administrators and EY in general have worked with Hilco on multiple previous insolvency appointments and therefore have a well-established relationship and are aware of the quality of their work and reliability of their agents.</p> <p>Their fees are also reasonable and in line with expectations.</p>
OHS Limited ("OHS")	Security	<p>The Joint Administrators have instructed OHS to secure the building and assets at the Sunderland site.</p> <p>OHS were recommended by Hilco as they have experience in this area of security and their fees are reasonable in line with expectations.</p>

## 6. Pre administration costs

The Administrators will be seeking approval for payment of unpaid pre administration costs totalling £227,953 (plus VAT). The payment of unpaid pre-administration costs as an expense of the administration is subject to approval under Rule 3.52, and not part of the Proposals subject to approval under paragraph 53. This means that they must be approved separately from the Proposals.

A breakdown of the total pre administration costs incurred and amounts paid pre administration (if any) is attached at Appendix D. Further information is provided below.

### **Joint Administrators' pre-appointment fees**

As noted in Section 1 of this report, EY was engaged by SGP, under an engagement agreement dated 13 November 2023, to undertake financial advisory and liquidity analysis. The scope was extended on 13 February 2024 to explore an accelerated sales process, with the aim of securing a solvent sale of the Group's business. In the event this was not successful a level of contingency planning was to be undertaken ahead of a potential administration appointment.

The work undertaken pre-appointment related to the following:

- ▶ Liaising with the Directors and senior management to understand the Companies' financial position, asset base and liabilities.
- ▶ Preparing an information memorandum to assist with the sale of the Companies' business and assets.
- ▶ Contacting potential parties that were identified as potentially having an interest in acquiring the Companies' business and assets. Providing non-disclosure agreements and details on the sales process to parties.
- ▶ Updating the Directors of the Companies on the sale process and expressions of interest.
- ▶ Monitoring the Companies' short term cash flow forecasts.
- ▶ Preparing a cash flow for cast and estimated outcome statements to assist with the formulation of the Administration strategy.
- ▶ Briefing the Joint Administrators' staff on the Administration strategy and day one actions.
- ▶ Preparing and reviewing documents to be issued to employees, creditors, members and directors following the appointment of the Joint Administrators.
- ▶ Reviewing and providing information for the preparation of the documents for the appointment of the Joint Administrators, including consents to act.
- ▶ Liaising with the Companies legal advisors regarding the potential appointment of Joint Administrators

Undertaking the above work enabled the post-appointment sales process to continue and preserved value in the Companies' business and assets.

The breakdown attached at Appendix D sets out:

- ▶ The fees and expenses charged by the Joint Administrator prior to appointment in relation to contingency planning.
- ▶ The fees and expenses charged by the Joint Administrators in relation to the accelerated sales process prior to appointment.

**Other pre-appointment costs incurred**

Fieldfisher provided legal advice to the Joint Administrators in connection with the insolvency appointment. This included preparing the statutory documentation to place the Companies into Administration, review and input into key communications to stakeholders, Fieldfisher's unpaid pre administration costs total £20,760 (plus VAT).



# Appendix A Statutory information

## Company Information

<b>Company Name:</b>	<b>Saietta Group Plc (in Administration)</b>
Registered Office Address:	c/o Ernst & Young LLP, The Paragon, 32 Counterslip, Bristol, BS1 6BX
Registered Number:	06744840
Trading Name:	N/A
Trading Address:	Unit 1500A, Silverstone Park, Silverstone, Towcester, Northamptonshire NN12 8FU

## Details of the Administrators and of their appointment

Administrators:	Lucy Winterborne and Daniel Christopher Hurd
Date of Appointment:	4 March 2024
By Whom Appointed:	The appointment was made by the Company's directors
Court Reference:	High Court of Justice, Business and Properties Court, of England and Wales, Insolvency and Companies List (ChD)

Any of the functions to be performed or powers exercisable by the Joint Administrators may be carried out/exercised by any one of them acting alone or by any or all of them acting jointly.

## Statement concerning the EU Regulation on Insolvency Proceedings

The proceedings are to which the EU Regulation as it has effect in the law of the United Kingdom does not apply.

## Summary of issued share capital and major shareholders\*

<b>Shareholder name</b>	<b>Total no. shares held</b>	<b>% shareholding</b>
EMMANUEL CLAIR	14,071,740	9.7%
FOREST NOMINEES LIMITED	12,259,380	8.4%
HSBC GLOBAL CUSTODY NOMINEE (UK) LIMITED	8,823,529	6.1%
HARGREAVES LANSDOWN (NOMINEES) LIMITED	8,431,099	5.8%
WINTERFLOOD SECURITIES LIMITED	6,445,234	4.4%
INTERACTIVE INVESTOR SERVICES NOMINEES LIMITED	6,014,530	4.1%
HARGREAVES LANSDOWN (NOMINEES) LIMITED	5,790,430	4.0%
Other	83,306,781	57.4%
	<b>145,142,723</b>	<b>100.0%</b>

## Directors and secretary and their shareholdings\*

<b>Name</b>	<b>Status</b>	<b>Date of appointment</b>	<b>Date of resignation</b>	<b>Current Shareholding</b>
Field Fisher Secretaries Limited	Company Secretary	24-Jun-21	-	-
EMMANUEL CLAIR	Director	23-Nov-23	-	14,071,740
WICHER KIST	Director	23-Nov-18	17-Apr-23	1,313,289
DEVYANI VAISHAMPAYAN	Director	05-Dec-22	-	117,647

Source: Share Registrar extract dated 6 March 2024

## Appendix A Statutory information

### Company Information

<b>Company Name:</b>	<b>Saietta Sunderland Plant Limited (in Administration)</b>
Registered Office Address:	c/o Ernst & Young LLP, The Paragon, 32 Counterslip, Bristol, BS1 6BX
Registered Number:	08242130
Trading Name:	N/A
Trading Address:	Mercantile Road, Rainton Bridge Industrial Estate, Houghton-le-Spring DH4 5PH

### Details of the Administrators and of their appointment

Administrators:	Lucy Winterborne and Daniel Christopher Hurd
Date of Appointment:	4 March 2024
By Whom Appointed:	The appointment was made by the Company's director
Court Reference:	High Court of Justice, Business and Properties Court, of England and Wales, Insolvency and Companies List (ChD)

Any of the functions to be performed or powers exercisable by the Joint Administrators may be carried out/exercised by any one of them acting alone or by any or all of them acting jointly.

### Statement concerning the EU Regulation on Insolvency Proceedings

The proceedings are to which the EU Regulation as it has effect in the law of the United Kingdom does not apply.

### Share capital

Class	Authorised		Issued and fully paid	
	Number	£	Number	£
A Ordinary	100	100	100	100

There are no director shareholdings

## **Appendix B      Directors' statement of affairs**

## Statement of affairs

Name of Company Saietta Group Plc	Company number 06744840
In the High Court of Justice, Business and Properties Court, of England and Wales, Insolvency and Companies List (ChD)	Court case number CR 2024 001341

(a) Insert name and address of registered office of the Company

Statement as to the affairs of (a) Saietta Group Plc (in Administration) ("the Company")

c/o Ernst & Young LLP, The Paragon, Counterslip, Bristol, BS1 6BX

(b) Insert date

on the (b)4 March 2024

, the date that the Company entered Administration.

### Statement of Truth

I believe that the facts stated in this statement of affairs are a full, true and complete statement of the affairs of the above named Company as (b) \_\_\_\_\_ the date that the company entered Administration.

Full name DAVID WILKINSON

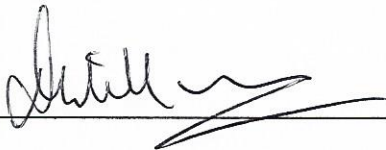
Signed 

Dated 25/4/2024

## A – Summary of Assets

Assets	Book Value (£)	Estimated to Realise (£)
Assets subject to fixed charge:		
Rights of use assets	5,327,046.78	1.00
Less amounts due to finance companies	<u>(5,616,613.65)</u>	
Deficit carried down to unsecured non-preferential claims	<b>(289,566.87)</b>	<b>Nil</b>
Assets subject to floating charge:		
Uncharged assets:		
Assets – Other		
Property, Plant and Equipment	2,196,379.29	1,665,000.00
Plant and Machinery	5,761,356.75	0
Assets under construction	1,110,911.85	0
Leasehold Improvements	44,786.04	0
Motor vehicles	69,344.19	0
Marketing/Website	90,242.62	10,000.00
IT equipment	27,990.38	0
Fixtures and fittings	9,683,157.49	850,000.00
Intangible Assets	494,079.91	1.00
Inventory	1,234,607.66	24,424.61
Trade receivables	441,320.92	0
Prepayments	2,094,150.74	270,000.00
Other receivables	823,414.15	823,414.15
Cash in bank	74,312.80	0
VAT recoverable	7,275,510.82	0
Intercompany loans		
Estimated total assets available for preferential creditors	<b>30,842,511.87</b>	<b>3,642,840.76</b>

Signature

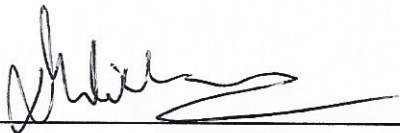

Date

25/4/2024

## A1 – Summary of Liabilities

		Estimated to realise (£)
<b>Estimated total assets available for preferential creditors (carried from page A)</b>		3,642,840.76
<b>Liabilities</b>	£	
Preferential creditors:-		
Primary preferential creditors	(49,727.87)	
Secondary preferential creditors	(127,732.43)	(177,460.30)
<b>Estimated deficiency/surplus as regards preferential creditors</b>	£	3,593,112.89
Estimated prescribed part of net property where applicable (to carry forward)	£0.00	0.00
<b>Estimated total assets available for floating charge holders</b>	£	3,593,112.89
Debts secured by floating charges	£0.00	0.00
<b>Estimated deficiency/surplus of assets after floating charges</b>	£	3,593,112.89
Estimated prescribed part of net property where applicable (brought down)	£0.00	0.00
<b>Total assets available to unsecured creditors</b>	£	3,593,112.89
Unsecured non-preferential claims (excluding any shortfall to floating charge holders)	£0.00	(4,747,593.58)
<b>Estimated deficiency/surplus as regards non-preferential creditors (excluding any shortfall to floating charge holders)</b>	£	(1,154,480.69)
Shortfall to floating charge holders (brought down)	£0.00	0.00
<b>Estimated deficiency/surplus as regards creditors</b>	£	(1,154,480.69)
Issued and called up capital	£	(113,209.49)
<b>Estimated total deficiency/surplus as regards members</b>	£	<b>(1,267,690.18)</b>

Signature

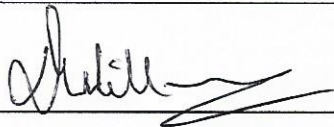

Date

25/4/2024

# COMPANY CREDITORS

**Note:** You must include all creditors and identify all creditors under hire-purchase, chattel leasing or conditional sale agreements *and* customers claiming amounts paid in advance of the supply of goods or services *and* creditors claiming retention of title over property in the company's possession. Claims by employees, former employees and consumers should be given as a single figure, with details provided on the respective schedules

Name of creditor or claimant	Address (with postcode)	Amount of debt £	Details of any security held by creditor	Date security given	Value of security £
Associated Production Tools Ltd	Unit 7 Carberry Court 28 Queen Elizabeth Avenue Millington Park, Glasgow G52 4NQ	(382.68)	n/a	n/a	n/a
ATLAS Facilities LTD	44 High March Daventry, Northamptonshire NN11 4HB	(2,152.82)	n/a	n/a	n/a
BC Electrical Techniques Ltd	Units 48-50 Edison Road Rabans Lane Industrial Estate Aylesbury, Bucks HP19 8TE	(1,482.19)	n/a	n/a	n/a
Blue Planet IT	Main Rd Middleton Cheney Banbury, Oxon OX17 2PW	(24,588.54)	n/a	n/a	n/a
Borland Insurance Ltd	Albion House Mitchelston Drive Kirkcaldy, Fife KY1 3LZ	(44,205.31)	n/a	n/a	n/a
Cherwell District Council	Revenues Department PO Box+C61 27 Banbury, Oxon OX15 4BH	(1,914.91)	n/a	n/a	n/a
Shanghai Consistent Magnetics Co. Ltd	No.5588 CaoAn Road Shanghai City	(493.66)	n/a	n/a	n/a
CPC Farnell	Component House Fulwood Preston, PR2 9PP	(186.19)	n/a	n/a	n/a
Cromwell Tools Ltd	65 Chartwell Drive Wigston, Leicester LE18 1AT	(407.20)	n/a	n/a	n/a
Croner Group Ltd	Croner House Wheatfield Way Hinckley, LE10 1YG	(544.90)	n/a	n/a	n/a
Culligan Water Limited	Trafalgar House Rash's Green Dereham, Norfolk NR19 1JG	211.58	n/a	n/a	n/a
DHL Direct Debit A/C 957061943 (IMPORT) /	PO Box 524 Hounslow, Middlesex TW3 9LP	(654.46)	n/a	n/a	n/a

DHL Acc 424858539 (EXPORT) / 425653375	DHL ACC 424858539 BACS	7.16	n/a	n/a	n/a
Digi-Key Corporation	701 Brooks Avenue South Thief River Falls, MN 56701	(71.62)	n/a	n/a	n/a
Electrified Automation Ltd	Unit 4 Beech Business Park Bristol Road Bridgwater, Somerset TA6 4FF	(67,551.12)	n/a	n/a	n/a
Farnell	Canal Road Leeds Leeds, W.Yorks LS12 2TU	(130.15)	n/a	n/a	n/a
Fieldfisher N.V.	Amsteldijk 220 1079 LK Netherlands	(8,835.26)	n/a	n/a	n/a
FTI Consulting LLP	200 Aldersgate Aldersgate Street London, London EC2M3UR	(21,600.00)	n/a	n/a	n/a
Grundon Waste Management Ltd	Thames House Oxford Road, Benson Wallingford, Oxon, OX10 6LX	(322.79)	n/a	n/a	n/a
Leaseplan UK Ltd	165 Bath Road Slough Berkshire, SL1 4AA	(10,677.12)	n/a	n/a	n/a
Livingstone Skies Ltd	Finsbury House New Street Chipping Norton, Oxon OX7 5LL	(768.48)	n/a	n/a	n/a
Marcus Webb Associates Ltd	Hampshire Hampshire, PO15 5TT	(6,750.00)	n/a	n/a	n/a
Nash & Co Capital Ltd	40 Craven Street London, WC2N 5NG	(57,600.00)	n/a	n/a	n/a
Orbital Fasteners Ltd	Olds Approach Tolpits Lane Watford, Hertfordshire WD18 9XT	(223.83)	n/a	n/a	n/a
Padmini VNA Mechatronics Pvt Ltd	Plot No. 100-101 Sector 35, HSIIDC Udyog Vihar Haryana, 122001	(9,268.55)	n/a	n/a	n/a
Reddie & Grose LLP	The White Chapel Building 10 Whitechapel High Street London, E1 8QS	(31,186.57)	n/a	n/a	n/a
Routeco Limited	Davy Avenue Knowlhill Milton Keynes, Bucks MK5 8HJ	(5,572.06)	n/a	n/a	n/a
RS Components Ltd	PO BOX 99 Corby Northampton, Northants NN17 9RS	(712.09)	n/a	n/a	n/a
S&L Consultants	S-170, Third Floor Pachsheel Park New Dehli 110017	(3,000.00)	n/a	n/a	n/a



ScrewFix Ltd (Trade UK) a/c 6331640023370950 - UH	Unit 2 Bicester Trade Park Telford Industrial Estate, Launton Road Bicester, Oxfordshire OX26 4LD	(20.49)	n/a	n/a	n/a
Siemens Financial Services ITD	Sefton Park, Bells Hill Stoke Poges , Buckinghamshire SL2 4JS	401.13	n/a	n/a	n/a
Staff Expenses		409.60	n/a	n/a	n/a
Three Bond Europe SAS	5 Newmarket Court Kingston Milton Keynes, Bucks MK10 0AG	(3,156.00)	n/a	n/a	n/a
Wicher Kist Exp		(280.65)	n/a	n/a	n/a
QSentence UG	Michael-Ott- Str19 D-70771	(6,373.42)	n/a	n/a	n/a
Supaklean	6 Taylors Close Bicester, Oxfordshire OX26 3HS	(408.00)	n/a	n/a	n/a
The NAV People	Vedbaek Ltd (t/as The NAV People) Beacon House, Winchester Road Burghclere, RG20 9JZ	(2,610.00)	n/a	n/a	n/a
Blue Arv Services Limited	Vision House 31 Kenton Harrow, HA3 8DS	(10,485.40)	n/a	n/a	n/a
Blue Ced Services Limited	Ryknild House 31 Kenton Harrow, HA3 8DS	(6,990.34)	n/a	n/a	n/a
Bridge Fibre Ltd	168 Cowley Road Cambridge, CB4 0DL	(600.00)	n/a	n/a	n/a
Vox Markets	The Hawthorns 6 North Road Cardiff, CF10 3DU	(10,458.90)	n/a	n/a	n/a
HubSpot Ireland Ltd	Knotel Floor 4, Clerks Court 18-20 Farringdon Lane London, EC1R 3AU	39.60	n/a	n/a	n/a
Milk & More (MoreCo Ltd)	Second Floor, Park View Riverside Way Camberley, GU15 3YL	(247.90)	n/a	n/a	n/a
ICS Cool Energy Ltd	ICS House, Stephenson Road Calmore Industrial Estate Totton, SO40 3SA	(7,285.29)	n/a	n/a	n/a
Amazon UK Ltd		(3,768.65)	n/a	n/a	n/a
Maxim Facilities Management	Unit 60 BIC Centre Sunderland, SR5 2TA	(12,002.24)	n/a	n/a	n/a

Carrylift Materials Handling	3 Peel Road West Pimbo Industrial Estate Skelmersdale, Lancashire WN8 9PT	(2,625.48)	n/a	n/a	n/a
Cable House	The Boundry Farndon Road Market Harbrough, Leicestershire LE16 9NP	(5,968.20)	n/a	n/a	n/a
BOC Ltd	Customer Service Centre p.o Box 12 Priestley Road Worsley, Manchester M28 2UT	(50.30)	n/a	n/a	n/a
City Electrical Factors LTD (CEF)	Registered Office: Georgina Mackie House 141 Farmer Ward Road Kenilworth, CV8 2SU	(820.67)	n/a	n/a	n/a
KASL Precision Engineering	Commerce Way Rainton Bridge Industrial Estate Houghton le spring, DH4 5PP	(14,181.60)	n/a	n/a	n/a
Ballicom Ltd	Ballicom House 16 Binley Road Gosford Green, CV3 1HZ	(69.90)	n/a	n/a	n/a
Sensor Methods Limited	160 Milton Road , Cambridge CB4 1LE	(1,080.00)	n/a	n/a	n/a
Edson Electronics Ltd	Unit 2 Coquet Enterprise Park , Amble NE65 0PE	(141.00)	n/a	n/a	n/a
Big Dug ltd	Green Lane Tewkesbury, Gloucestershire GL20 8HD	(98.05)	n/a	n/a	n/a
Share Registrars Ltd	The Courtyard 17 West Street Farnham, Surrey GU9 7DR	(4,076.64)	n/a	n/a	n/a
Emsiso d.o.o.	Pesnica pri Mariboru 20a SI-2211 Pesnica pri Mariboru Slovenia	334,191.39	n/a	n/a	n/a
Absolute Automation LTD	Unit 19 Silver Birches Business Park Bromsgrove, B60 3EU	(9,990.00)	n/a	n/a	n/a
Canaccord Genuity Ltd	88 Wood Street London, EC2V 7QR	(22,521.00)	n/a	n/a	n/a
Mark Rathore PSC Limited	1B The Green , NN7 4LG	(233.60)	n/a	n/a	n/a
3C Test Limited	Silverstone Circuit Silverstone Technology Park Northants, NN12 8GX	(19,293.60)	n/a	n/a	n/a
Hottinger Bruel & Kjaer UK Ltd	Brunel Way Rotherham, S60 5WG Great Britain	(7,050.03)	n/a	n/a	n/a
Northants Fluid Power Ltd	75 Tenter Road Northampton, NN3 6AX Great Britain	(1,132.44)	n/a	n/a	n/a

Fieldfisher LLP	Riberbank House 2 Swan Lane London, EC4R 3TT	24,000.00	n/a	n/a	n/a
Schaltbau Machine Electrics	Units 335-336 Springvale Industrial Estate Woodside Way Cwmbran, NP44 5BR	(8,365.38)	n/a	n/a	n/a
RABB-IT Ltd	Ground Floor Unit 4 The Scribbling House Leeds, West Yorkshire LS28 5QS	(3,504.00)	n/a	n/a	n/a
Fed Ex UK Ltd Acc 687784065	Express House Holly Lane , CV9 2RY	142.86	n/a	n/a	n/a
Emfast Limited	Emfast House, 101 Sanders Road Finedon Road Industrial Estate Wellingborough Road, Northamptonshire NN8 4NL	(162.70)	n/a	n/a	n/a
Gardner Leader	██	827.00	n/a	n/a	n/a
Bourton Drain Services Limited	Unit 15 Beaumont Business Centre Beaumont Close , OX161TN	(162.00)	n/a	n/a	n/a
JLCPCB (Jiali Chuang Hong Kong Co Ltd)	Unit 21 28/F Metropole Square No 2 On Yiu Street Shatin China	0.11	n/a	n/a	n/a
London Stock Exchange	10 Paternoster Square London, EC4M 7LS Great Britain	(20,042.40)	n/a	n/a	n/a
HV Wooding Limited	Range Road Industrial Estate Hythe, Kent CT21 6HG	(21,228.24)	n/a	n/a	n/a
Aurora Managed Services Ltd	1-25 Castle Lane London, SW1E6DR Great Britain	(241.52)	n/a	n/a	n/a
Zest4	50 Alderly Road Wilmslow Cheshire, SK91NY	(726.46)	n/a	n/a	n/a
Adobe Systems Software Ireland Ltd (IE)	4-6 Riverwalk Citywest Business Park Dublin	83.03	n/a	n/a	n/a
PAR Insulations & Wires Ltd	Foxwood Close Foxwood Industrial Park Chesterfield, S41 9RB	(12,202.51)	n/a	n/a	n/a
The Print Factory	Moreland Street Hartlepool , TS247NL Great Britain	(76.80)	n/a	n/a	n/a
Computer Pro	The Old Forge Building North Green Kirtlington, OX5 3JZ	(144.00)	n/a	n/a	n/a
Solid Print 3D ITD	Building 500 Abbey Park Stareton, Kenilworth, Warwickshire CV8 2LY	(450.00)	n/a	n/a	n/a

AIG Llife Limited	58 Fenchurch St London, EC3M 4AB Great Britain	3,605.40	n/a	n/a	n/a
Curtis Instruments UK	5 Upper Priory Street Northampton, Northamptonshire NN1 2PT	(22,344.00)	n/a	n/a	n/a
Dial a Bin Ltd	Blackpitts Barn Welsh Lane Brackley, NN13 5QD	(480.00)	n/a	n/a	n/a
BACA Workwear & Safety LTD	Direct House, Clayfield Close Moulton Park Industrial Estate Northampton, NN36QN	(199.94)	n/a	n/a	n/a
Meter Mix Systems LTD	Brindley Close Rushden Business Park Rushden, NN106EN	(7,822.80)	n/a	n/a	n/a
Jagdev Engineering Solutions Pvt Ltd	Sitarpur, Derabassi Tehsil, SAS Nagar District Lalru, 140501 India	(7,047.71)	n/a	n/a	n/a
Ground Control Limited	Kingfisher House 1 Radford Way Billericay, CM12 0EQ	(1,468.20)	n/a	n/a	n/a
BDO LLP	55 Baker Street London, W1U 7EU Great Britain	(63,000.00)	n/a	n/a	n/a
Shire Leasing Plc	Calico Business Park Sandy Way Tamworth, , Staffordshire B77 4BF	55.46	n/a	n/a	n/a
Huddersfield Bearings Ltd (Bearings R Us)	Units 10 & 11 St Andrews Court Huddersfield, HD1 6QB	(29.88)	n/a	n/a	n/a
R & D Clarke Precision Engineers Ltd	22-24 Lanchester Way Royal Oak Industrial Estate Daventry, NN11 8PH	(2,092.50)	n/a	n/a	n/a
"Ellsworth Adhesives Europe		(771.06)	n/a	n/a	n/a
EDF Energy	Barnwood, Gloucester GL4 3SA	6.40	n/a	n/a	n/a
Unico (UK) Limited	Garamonde Drive Wymbush Milton Keynes, MK8 8LF	(24,606.00)	n/a	n/a	n/a
Saietta Sunderland	Mercantile Road Houghton-le-Spring Tyne& Wear, DH4 5PH	(12,083.62)	n/a	n/a	n/a
AVTEC Limited (INR)	Pithampur Industrial Area, Sector III, Pithampur, Sagore Dhar. Madhya Pradesh. 454774	(103,840.00)	n/a	n/a	n/a
Sunderland City Council	Jack Crawford House, Commercial Rd, Hendon, Sunderland SR2 8QR	(470,120.00)	n/a	n/a	n/a

British Gas A/C 603686003	4440 John Smith Dr, Oxford OX4 2LL	(10,587.20)	n/a	n/a	n/a
Enterprise Rent A Car UK	Enterprise House Vicarage Road Egham, TW209FB	60.00	n/a	n/a	n/a
Opus Energy	Opus Energy House 8-10 The Lakes Northampton, NN4 7YD	(388.97)	n/a	n/a	n/a
Octopus Electric Vehicles Ltd	2nd Floor UK House 164-182 Oxford St london, W1D 1NN	(2,100.40)	n/a	n/a	n/a
Black and Callow Limited	80 Coleman St london, EC2R 5BJ Great Britain	(1,362.00)	n/a	n/a	n/a
Nedschroef Fasteners Ltd	Unit1 Network Sandy Lane W, Littlemore Oxford, OX4 6JU	(136.63)	n/a	n/a	n/a
GFM (UK) Ltd	Unit C1 Baird Court Park Farm Wellingborough, NN8 6QJ	(955.20)	n/a	n/a	n/a
Wilkinson Dynamic Balancing Ltd	Unit E1 Coombswood business park Coombswood Way Halesowen, West midlands, B62 8BH	(923.94)	n/a	n/a	n/a
Novatech Measurements Limited	83 Castleham Road St Leonards-on-Sea, TN389NT Great Britain	(1,674.72)	n/a	n/a	n/a
OSE European Ltd	Unit 1 H Nichol Yard South Shore Road Gateshead, Tyne and Wear, NE83AE	(2,729.57)	n/a	n/a	n/a
Wave Utilities	Salvus House, Aykley Heads, Durham DH1 5TS	(4,365.76)	n/a	n/a	n/a
Abbey Precision Ltd	72 Alston Drive Bradwell Abbey Milton Keynes, MK13 9HG	(769.73)	n/a	n/a	n/a
LCD Lasercut AG	Kaisermatt 3 5026 Densbueren Switzerland	(37,962.13)	n/a	n/a	n/a
Vitality Health	3 More London Riverside London, SE1 2AQ	(953.96)	n/a	n/a	n/a
DirectorsTalk	42 Parkwood Road Bournemouth, BH5 2BL Great Britain	(2,880.00)	n/a	n/a	n/a
"Portakabin Limited		(2,901.63)	n/a	n/a	n/a
Influence Associates Limited	22 Soho Square London, W1D 4NS Great Britain	(15,415.45)	n/a	n/a	n/a

GE Precision Engineering Ltd t/a Alcon Specialist	57 St James Mill Road Northampton, NN5 5JP Great Britain	708.00	n/a	n/a	n/a
Macildowie Associates Limited	Waterfront House Station Street Nottingham, NG2 3DQ	(7,200.00)	n/a	n/a	n/a
ME&D LTD (ESun)	134 Centurion House London Road, Staines-Upon-Thames Staines Surrey, TW18 4AX	90.45	n/a	n/a	n/a
Misumi Europa GmbH	Franklinstr 61-63 60486 Frankfurt	(674.22)	n/a	n/a	n/a
Trafalgar Cases	Stanhope Works, Primrose Hill Kings Langley , WD48HS	(188.28)	n/a	n/a	n/a
BT (British Telecom) Acc WM 4247 7545	81 Newgate Street London, EC1A 7AJ Great Britain	(684.00)	n/a	n/a	n/a
Fed Ex UK Ltd Acc 720694573	Badgers Rise, Ridgmont, Brogborough, Bedford MK43 0UL	(7,300.43)	n/a	n/a	n/a
Research Tree Ltd	1 Cornhill London, EC3V3ND Great Britain	(4,620.00)	n/a	n/a	n/a
Altair Engineering Ltd	Imperial House Holly Walk Lemington Spa, CV32 4JG	(54,000.00)	n/a	n/a	n/a
Oxford Bearings Ltd	Unit 14 Penhill Industrial Park Banbury, OX16 1RW Oxfordshire	(1,411.80)	n/a	n/a	n/a
The MathWorks Ltd	1 Cambridge Science Park Milton Road Cambridge, CB4 0JL	(5,880.00)	n/a	n/a	n/a
Capital Access Group Ltd	1 Cornhill London, EC3V 3ND Great Britain	(14,400.00)	n/a	n/a	n/a
Screwfix Ltd (Trade UK) a/c 6331640023805971 - SL	Screwfix Houghton-le-Spring, Unit 4, Rainton Bridge Industrial Estate, Mercantile Rd. Houghton le Spring DH4	(69.77)	n/a	n/a	n/a
Metacompliance Ltd	Third Floor Old City Factory, 100 Patrick Street Derry, Belfast BT48 7EL	(5,304.00)	n/a	n/a	n/a
Premier Precision Tooling Ltd	Havant Road Waterloovile , PO8 0DT	(2,370.00)	n/a	n/a	n/a
CSS Electronics	Soeren Frichs Vej 38K 8230 Aabyhoej Denmark	(1,180.93)	n/a	n/a	n/a
Saietta VNA Pvt Ltd	Plot No. 100-101, Sector 35 HSIIDC Udyog Vihar Phase VII, Gurgaon Har yana. Har yana. 122001	(806.55)	n/a	n/a	n/a

Graham Lenden Expenses GRP		(169.20)	n/a	n/a	n/a
Peterlee Fire Company Limited	Unit 6 Seaview Industrial Estate Horden , County Durham, SR8 4TQ Great Britain	(1,274.40)	n/a	n/a	n/a
HCL Technologies Limited (STPI Unit)	No. 8 MTH Road, Ambattur Industrial Estate Chennai, 600058 India	(294,534.00)	n/a	n/a	n/a
HCL Technologies Limited (EOU Unit)	Plot No. 73 & 74, Ambattur Industrial Estate Chennai, 600058 India	(31,064.00)	n/a	n/a	n/a
British Gas A/C 603686121	4440 John Smith Dr, Oxford OX4 2LL	(7,217.98)	n/a	n/a	n/a
British Gas A/C 603686152	4440 John Smith Dr, Oxford OX4 2LL	250.97	n/a	n/a	n/a
Campaign Monitor (Marigold)	Campaign Monitor Europe Uk Ltd, 10 Lower Thames St, London EC3R 6EN	72.61	n/a	n/a	n/a
Knight Cleaning Services Ltd	Unit 5, York Farm Business Park Wating Street Towcester, NN12 8EU	(5,484.50)	n/a	n/a	n/a
ENL Limited	Unit 6-9 Victory Trading Estate Kiln Road Portsmouth, PO3 5LP	(7,872.00)	n/a	n/a	n/a
ETAS GmbH	Borsigstrasse 24 70469 Stuttgart	(3,206.00)	n/a	n/a	n/a
Das Gakhal Expenses LDE		(22.18)	n/a	n/a	n/a
Inseto (UK) Ltd	Unit 25 Focus 303 Business Centre Andover, SP10 5NY Great Britain	(82.80)	n/a	n/a	n/a
Mehul Harji Expenses LDE		(0.50)	n/a	n/a	n/a
Interpump Fluid Solutions	Unit 5 Greenhill Industrial Estate Birmingham Road Kidderminster, DY10 2RN	23.44	n/a	n/a	n/a
Ucreate PCB Co., Ltd	Longcheng Street Longgang District 518100 ShenZhen City	(1,084.00)	n/a	n/a	n/a
Testemp Ltd	Rope Walk Littlehampton West Sussex, BN17 5DE	(718.92)	n/a	n/a	n/a
The Society of Motor Manufacturers and Traders	71 Great Peter Street London, SW1P 2BN Great Britain	(120.00)	n/a	n/a	n/a

Landfill Alternatives Ltd	Woodend Grange Brackley, NN13 5NS	(288.00)	n/a	n/a	n/a
PERFORM LOGISTICS	UNIT C5, OCTIMUM BUSINESS PARK FORSYTHE ROAD WOKING, GU21 5SF	118.98	n/a	n/a	n/a
The Barcode Warehouse Ltd	Telford Drive Newark, NG24 2DX Great Britain	(0.01)	n/a	n/a	n/a
AVTEC Limited (GBP)	Pithampur Industrial Area, Sector III Pithampur, Sagore Dhar, Madhya Pradesh. 454774	(53,925.77)	n/a	n/a	n/a
BT (British Telecom) Acc GP01109819	British Telecom, 75-77 St Michael's St, Tyburnia, London W2 1QS	(52.74)	n/a	n/a	n/a
ROKILL LTD	ROSSLAND HOUSE SALISBURY HOUSE, RINGWOOD , BH24 3PB	(180.00)	n/a	n/a	n/a
Aviva Credit Services UK Ltd	GI Collections PO Box 3471, Surrey Street Norwich, NR1 3FZ	(9,720.77)	n/a	n/a	n/a
AR United Kingdom	Unit 8 Madingley Court Chippenham Drive Milton Keynes, MK10 0BZ	(1,537.58)	n/a	n/a	n/a
Weiss Technik UK Ltd	Units 37-38 Loughborough Technology Centre Epinal Way Loughborough. LE11 3GE	(13,999.86)	n/a	n/a	n/a
SILVERSTONE FACTORS LTD	SILVERSTONE CIRCUIT Silverstone, NN12 8TL Great Britain	(0.20)	n/a	n/a	n/a
Opus Talent Solutions	Merchants House 4th Floor Wapping Road Bristol, BS1 4RW	(73,905.00)	n/a	n/a	n/a
Periscope Live LTD	The Old Boatyard Daventry, NN11 4PH	(10,599.08)	n/a	n/a	n/a
Buckinghamshire Council	Walton Street Aylesbury, HP20 1UA	(33,582.00)	n/a	n/a	n/a
Smiths High Performance	UNIT 3 JUNO PLACE STRATTON BUSINESS PARK BIGGLESWADE, BEDFORDSHIRE SG18 8XP	(2,624.14)	n/a	n/a	n/a
Erode-All Limited	20 Queens Road High Wycombe, Bucks HP13 6AQ	(5,136.00)	n/a	n/a	n/a
Fed Ex 201232710	Badgers Rise, Ridgmont, Brogborough, Bedford MK43 0UL	128.69	n/a	n/a	n/a
Aztech Ltd	UNIT 3, YORK ROAD RICCALL YORK, YORKSHIRE YO19 6QQ	(514.80)	n/a	n/a	n/a



Alan Spargo Limited	Coronation Road Cressex Business Park High Wycombe, HP12 3TA	(4,368.00)	n/a	n/a	n/a
Norman Broadbent Executive Search	Finance Department Millbank Tower, 21-24 Millbank London, SW1P 4QP	(56,800.00)	n/a	n/a	n/a
Blue Gnu Consulting Ltd	Ashfield House Grange Road Aldershot, Surrey GU12 6HB	(2,700.00)	n/a	n/a	n/a
RUTRONIK UK LTD	1-3 Courtyard, Calvin Street Bolton , BL1 8PB Lancashire	(2,414.83)	n/a	n/a	n/a
Aqua Cooling Ltd	Unit 6 Brickfield Lane, Chandlers Ford Eastleigh, SO53 4DP Great Britain	(1,202.40)	n/a	n/a	n/a
Stable Fabrication Ltd	1 Foundry Place Old Tiffeld Road Towcester, NN12 6FP	(2,017.80)	n/a	n/a	n/a
In Professional Development Limited	Suite 6A Blackthorn House Appley Bridge, Wigan, WN6 9DB Great Britain	(1,428.00)	n/a	n/a	n/a
SoloProtect LTD	1 Vantage Drive Sheffield, S9 1RG	(396.00)	n/a	n/a	n/a
Norelem LTD	Innovation Centre 1 Devon Way Birmingham, B31 2TS	(29.15)	n/a	n/a	n/a
KADEL Engineering Ltd	Ingrow Bridge, Halifax Road Keighley, BD21 5DZ	(192.00)	n/a	n/a	n/a
eSun - Shenzhen Esun Industrial Co., Ltd.	Wuhan University Building A403-I and A901, No.6 Yuexing 2 Road. Nanshan District Shenzhen	(90.44)	n/a	n/a	n/a
Bowers Electrical Engineering Services Ltd	Unit 1 Dallington Field Business Park Kings Heath Industrial Estate Northampton, NN5 7QD	(4,320.00)	n/a	n/a	n/a
Freight Logistics Solutions	Skewfields, Lowermill Pontypool Torfaen, NP4 0XZ	(1,956.00)	n/a	n/a	n/a
J Eloff Exp		(39.94)	n/a	n/a	n/a
DEMAK SRL	Strada del Cascinotto, 163 10156 Torino Italy	(1,705.32)	n/a	n/a	n/a
SKF (U.K.) LTD	SUNDON PARK ROAD LUTON, LU3 3BL	(523.20)	n/a	n/a	n/a
FABORY UK LIMITED	Block D, Bay 9, The Bescot Estate Wednesbury, WS10 7SG	(29.71)	n/a	n/a	n/a

The SFS Manufacturing Group Ltd	Unit 3 Finway Luton, LU1 1TR	(644.82)	n/a	n/a	n/a
European Automation Ltd	3 Parker Court Staffordshire Technology Park Stafford, ST18 0WP	(655.20)	n/a	n/a	n/a
Copier Co	Unit 50, Sandford Lane Ind Est, Kennington, Oxford, OX1 5RP Great Britain	(97.52)	n/a	n/a	n/a
Tyres Northampton	Tyne Road Weedon Road Industrial Estate Northampton, NN5 5AF Great Britain	369.99	n/a	n/a	n/a
Shrives Wright Ltd	The Old Stables Church Lane, Dingley, Market Harborough,, LE16 8PG	(540.00)	n/a	n/a	n/a
TASKING Germany GmbH	Streitfeldstrasse 19 81673 Munich	(4,340.04)	n/a	n/a	n/a
Opus Energy	Opus Energy House 8-10 The Lakes Northampton, NN4 7YD	(8,482.81)	n/a	n/a	n/a
Lambert Smith Hampton	Suite 3, First Floor, Whichford House, Parkway Court, Oxford, OX4 2JY	(35,204.69)	n/a	n/a	n/a
Airworks Compressors Corp.	14503 - 115 Ave NW, Edmonton AB T5M 3B8	(2,205.30)	n/a	n/a	n/a
Ayro Inc	900 E Old Settlers Blvd, Round Rock, TX 78664	(37,539.95)	n/a	n/a	n/a
Saietta VNA Private Limited	Plot No: 108, Sector - 8, IMT Manesar. Gurgaon - 122050. Harvana. India	(199500.00)	n/a	n/a	n/a
Amperino Otomotiv Mekatronik San. Tic. A.S.	Süleymaniyeosb Mah Erhun Metal Fabrikası 1. Caddesi No 37 16400 Süleymanive Osb/İnegöl/Bursa	(9,000.00)	n/a	n/a	n/a
CNC International Services Ltd	Business Park Wyastone Leys, Monmouth NP25 3SR	(8250.00)	n/a	n/a	n/a
Saietta VNA Private Limited	Plot No: 108, Sector - 8, IMT Manesar. Gurgaon - 122050. Harvana. India	(1500458.00)	n/a	n/a	n/a
Powerall	Unit 3A, Birch Park, York YO31 9BL	(11600.00)	n/a	n/a	n/a
ET acquisition payable		(260128.44)	n/a	n/a	n/a
Intercompany: Saietta Holding B.V.	Intercompany: Saietta Holding B.V.	(85.00)	n/a	n/a	n/a

Intercompany: Saietta Europe B.V. (e-Traction Europe B.V.)	Intercompany: Saietta Europe B.V. (e-Traction Europe B.V.)	(14706.84)	n/a	n/a	n/a
HMRC – unsecured estimate		(167,137.59)	n/a	n/a	n/a
HMRC – secondary preferential estimate		(127,732.43)	n/a	n/a	n/a
Deficit from ROI assets		(289,566.87)	Assets on hire/lease	n/a	n/a

Signature



Date

25/4/24

# COMPANY SHAREHOLDERS

InvestorName	No-ORDINARY SHARES of 0.1	AddressLine1	AddressLine2	AddressLine3	PostCode
EMMANUEL CLAIR	14,071,740				
FOREST NOMINEES LIMITED	12,259,380	P.O. BOX 328	ST PETER PORT	GUERNSEY	GY1 3TY
HSBC GLOBAL CUSTODY NOMINEE (UK) LIMITED	8,823,529	8 CANADA SQUARE	LONDON		E14 5HQ
HARGREAVES LANSDOWN (NOMINEES) LIMITED	8,431,099	ONE COLLEGE SQUARE SOUTH	ANCHOR ROAD	BRISTOL	BS1 5HL
WINTERFLOOD SECURITIES LIMITED	6,445,234	THE ATRIUM BUILDING	CANNON BRIDGE	25 DOWGATE HILL	EC4R 2GA
INTERACTIVE INVESTOR SERVICES NOMINEES LIMITED	6,014,530	201 DEANSGATE	MANCHESTER	ENGLAND	M3 3NW
HARGREAVES LANSDOWN (NOMINEES) LIMITED	5,790,430	ONE COLLEGE SQUARE SOUTH	ANCHOR ROAD	BRISTOL	BS1 5HL
BNY (OCS) NOMINEES LIMITED	5,364,232	ONE PICCADILLY GARDENS	MANCHESTER		M1 1RN
INTERACTIVE INVESTOR SERVICES NOMINEES LIMITED	4,210,739	201 DEANSGATE	MANCHESTER	ENGLAND	M3 3NW
HARGREAVES LANSDOWN (NOMINEES) LIMITED	3,812,043	ONE COLLEGE SQUARE SOUTH	ANCHOR ROAD	BRISTOL	BS1 5HL
BARCLAYS DIRECT INVESTING NOMINEES LIMITED	3,755,213	1 CHURCHILL PLACE	LONDON		E14 5HP
VESTRA NOMINEES LIMITED	3,362,963	14 CORNHILL	LONDON		EC3V 3NR
FREETRADE NOMINEES LIMITED	3,344,261	10 DEVEONSHIRE SQUARE	LONDON		EC2M 4YP
HSDL NOMINEES LIMITED	3,018,580	TRINITY ROAD	HALIFAX		HX1 2RG
THE BANK OF NEW YORK (NOMINEES) LIMITED	2,625,497	ONE PICCADILLY GARDENS	MANCHESTER		M1 1RN
HSDL NOMINEES LIMITED	2,193,382	TRINITY ROAD	HALIFAX		HX1 2RG
CGWL NOMINEES LIMITED	2,119,804	88 WOOD STREET	LONDON		EC2V 7QR
INTERACTIVE BROKERS LLC	1,912,717	FLOOR 12	20 FENCHURCH STREET	LONDON	EC3M 3BY
KIM ERIK LLOYD	1,769,265				
SEGURO NOMINEES LIMITED	1,602,735	BIRCHIN COURT	20 BIRCHIN LANE	LONDON	EC3V 9DU
WILLIAM PHELPS	1,588,915				
PAUL PREECE	1,567,244				
LAWSHARE NOMINEES LIMITED	1,525,143	4 EXCHANGE QUAY	SALFORD QUAYS	MANCHESTER	M5 3EE
AURORA NOMINEES LIMITED	1,436,056	10 HAREWOOD AVENUE	LONDON		NW1 6AA
THE BANK OF NEW YORK (NOMINEES) LIMITED	1,380,989	ONE PICCADILLY GARDENS	MANCHESTER		M1 1RN
INTERACTIVE INVESTOR SERVICES NOMINEES LIMITED	1,341,226	201 DEANSGATE	MANCHESTER	ENGLAND	M3 3NW
WICHER KIST	1,313,289				
OLIVER HAGGER	1,266,224				
BNY (OCS) NOMINEES LIMITED	1,214,275	ONE PICCADILLY GARDENS	MANCHESTER		M1 1RN

Signature

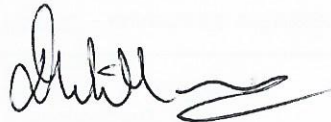

Date 25/4/24

LAWSHARE NOMINEES LIMITED	1,182,710	4 EXCHANGE QUAY	SALFORD QUAYS	MANCHESTER	M5 3EE
ROCK (NOMINEES) LIMITED	1,176,082	55 BISHOPSGATE	LONDON		EC2N 3AS
JIM NOMINEES LIMITED	1,174,662	78 MOUNT EPHRAIM	TUNBRIDGE WELLS	KENT	TN4 8BS
NORTRUST NOMINEES LIMITED	1,131,713	50 BANK STREET	CANARY WHARF	LONDON	E14 5NT
JOH BERENBERG GOSSLER & CO KG	1,098,630	C/O BNP PARIBAS LONDON BRANCH	10 HAREWOOD AVENUE	LONDON	NW1 6AA
NASH & CO NOMINEES LTD	1,083,625	4TH FLOOR	50 MARK LANE	LONDON	EC3R 7QR
MR RAHOUL KABIR BHANDARI	1,029,412				
MRS SONIA PARSHAD BHANDARI	1,029,412				
SEGURO NOMINEES LIMITED	982,205	BIRCHIN COURT	20 BIRCHIN LANE	LONDON	EC3V 9DU
JIM NOMINEES LIMITED	971,362	78 MOUNT EPHRAIM	TUNBRIDGE WELLS	KENT	TN4 8BS
CANACCORD NOMINEES LIMITED	906,044	C/O BNP PARIBAS LONDON BRANCH	10 HAREWOOD AVENUE	LONDON	NW1 6AA
WINTERFLOOD CLIENT NOMINEES LIMITED	891,472	THE ATRIUM BUILDING	CANNON BRIDGE HOUSE	25 DOWGATE HILL	EC4R 2GA
MRS VIVEKA BHANDARI	882,352				
SMITH & WILLIAMSON NOMINEES LIMITED	873,103	206 ST VINCENT STREET	GLASGOW		G2 5SG
ROCK (NOMINEES) LIMITED	734,574	55 BISHOPSGATE	LONDON		EC2N 3AS
SEGURO NOMINEES LIMITED	684,540	BIRCHIN COURT	20 BIRCHIN LANE	LONDON	EC3V 9DU
HSDL NOMINEES LIMITED	636,897	TRINITY ROAD	HALIFAX		HX1 2RG
PUMA NOMINEES LIMITED	602,878	C/O PERSHING LIMITED	ROYAL LIVER BUILDING	PIER HEAD	L3 1LL
RATHBONE NOMINEES LIMITED	594,335	PORT OF LIVERPOOL BUILDING	PIER HEAD	LIVERPOOL	L3 1NW
VIDACOS NOMINEES LIMITED	567,932	CITIGROUP CENTRE	CANADA SQUARE	CANARY WHARF	E14 5LB
FERLIM NOMINEES LIMITED	561,796	100 OLD HALL STREET	LIVERPOOL		L3 9AB
GRAHAM LENDEN	531,885				
HSBC CLIENT HOLDINGS NOMINEE (UK) LIMITED	508,621	8 CANADA SQUARE	LONDON		E14 5HQ
HSDL NOMINEES LIMITED	497,456	TRINITY ROAD	HALIFAX		HX1 2RG
UBS PRIVATE BANKING NOMINEES LTD	489,460	5 BROADGATE	LONDON		EC2M 2AN
VIDACOS NOMINEES LIMITED	477,876	CITIGROUP CENTRE	CANADA SQUARE	CANARY WHARF	E14 5LB
EMBARK INVESTMENT SERVICES NOMINEES LIMITED	465,939	TYMAN HOUSE	42 REGENT ROAD	LEICESTER	LE1 6YJ
MORITZ PHILIPP HEDRICH	444,942				
VERONIKA SABINE SCHAEFFLER	444,942				
MORGAN STANLEY CLIENT SECURITIES NOMINEES LIMIT	430,418	25 CABOT SQUARE	CANARY WHARF	LONDON	E14 4QA

Signature

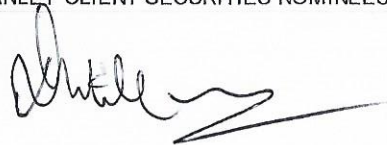

Date

25/4/24

LAWSHARE NOMINEES LIMITED	371,821	4 EXCHANGE QUAY	SALFORD QUAYS	MANCHESTER	M5 3EE
ROBERT CRABBE	357,824				
CHRIS LINES	313,222				
AURORA NOMINEES LIMITED	289,138	10 HAREWOOD AVENUE	LONDON		NW1 6AA
ROBERT ANTHONY CRABBE	284,900				
VINMAR INVESTMENTS LIMITED	284,900	PO BOX 602	LA PLAIDERIE HOUSE	ST PETER PORT	GY1 4NL
PLATFORM SECURITIES NOMINEES LTD	268,260	C/O F I S CORPORATE GOVERNANCE	THE WALBROOK BUILDING	25 WALBROOK	EC4N 8AF
WANDA CATHERINE RIX	248,333				
CHRISTOPHER RIX	248,235				
MARK TAYLOR	237,416				
DAVID NAYLOR-LEYLAND	200,000				
JOHN GEORGE RADWAY RIX	190,000				
YOMNA BAKRY	189,934				
TOM BENNETT	189,934				
REDMAYNE (NOMINEES) LIMITED	180,466	9 BOND COURT	LEEDS		LS1 2JZ
CHARLES BUTTER	150,000				
WINTERFLOOD CLIENT NOMINEES LIMITED	149,838	THE ATRIUM BUILDING	CANNON BRIDGE HOUSE	25 DOWGATE HILL	EC4R 2GA
PLATFORM SECURITIES NOMINEES LTD	138,080	C/O F I S CORPORATE GOVERNANCE	THE WALBROOK BUILDING	25 WALBROOK	EC4N 8AF
GOLDMAN SACHS SECURITIES (NOMINEES) LIMITED	129,229	PLUMTREE COURT	25 SHOE LANE	LONDON	EC4A 4AU
MS LUCY HART	124,394				
JAMIE HART	124,393				
DEVYANI VAISHAMPAYAN	117,647				
CHASE NOMINEES LIMITED	112,423	PO BOX 7732	1 CHASESIDE	BOURNEMOUTH	BH1 9XA
VINOD DESAI	112,000				
MICHAL GRIEGER	107,062				
OLGA PAK	106,838				
VLADIMIR SHEGAI	106,838				
ARVIND RABADIA	100,000				
DAVYCREST NOMINEES	100,000	DAVY HOUSE	49 DAWSON STREET	DUBLIN 2	
PERSHING NOMINEES LIMITED	100,000	THE ROYAL LIVER BUILDING	PIER HEAD	LIVERPOOL	L3 1LL

Signature



Date

25/4/24

PERSHING NOMINEES LIMITED	98,837	THE ROYAL LIVER BUILDING	PIER HEAD	LIVERPOOL	L3 1LL
IDEALING NOMINEES LIMITED	98,550	FINSBURY HOUSE	23 FINSBURY CIRCUS	LONDON	EC2M 7EA
PERSHING NOMINEES LIMITED	93,193	THE ROYAL LIVER BUILDING	PIER HEAD	LIVERPOOL	L3 1LL
CHASE NOMINEES LIMITED	92,344	PO BOX 7732	1 CHASESIDE	BOURNEMOUTH	BH1 9XA
HSDL NOMINEES LIMITED	92,077	TRINITY ROAD	HALIFAX		HX1 2RG
STEPHEN MILLS	85,470				
NATALIE SAVILLE	85,470				
REDMAYNE (NOMINEES) LIMITED	83,525	9 BOND COURT	LEEDS		LS1 2JZ
SALLY RIX	73,824				
VIDACOS NOMINEES LIMITED	72,561	CITIGROUP CENTRE	CANADA SQUARE	CANARY WHARF	E14 5LB
EMBARK INVESTMENT SERVICES NOMINEES LIMITED	65,480	8 WEST MARKETGAIT	DUNDEE		DD1 1QN
DR WENYUAN WANG	62,188				
LION NOMINEES LIMITED	60,200	NELSON HOUSE	GADBROOK BUSINESS CENT	GADBROOK ROAD	CW9 7TN
DAVID RIX	58,824				
FELIX POLE	56,980				
MORGAN STANLEY CLIENT SECURITIES NOMINEES LIMIT	56,903	25 CABOT SQUARE	CANARY WHARF	LONDON	E14 4QA
MICHAEL CAMPBELL	56,800				
HUNTRESS (CI) NOMINEES LIMITED	55,000	C/O PERSHING LIMITED	ROYAL LIVER BUILDING	PIER HEAD	L3 1LL
CHARLES POPE	54,019				
ADELE WHITE	54,019				
PAUL DARRELL WHITE	54,019				
HEATHER FRANKLIN	53,419				
RICHARD FRANKLIN	53,419				
ALBERTUS JANSEN	53,334				
RICHARD BRIGHT	52,118				
GORDON LINDSAY	50,000				
CEDRIC LYNCH	50,000				
THOMAS GRANT AND COMPANY NOMINEES LIMITED	50,000	40A FRIAR LANE	LEICESTER		LE1 5RA
HSBC GLOBAL CUSTODY NOMINEE (UK) LIMITED	47,484	8 CANADA SQUARE	LONDON		E14 5HQ
MICHAEL ROBSON	47,483				

Signature



Date 25/4/24

HALB NOMINEES LIMITED	43,000	33 GREAT CHARLES STREET	BIRMINGHAM		B3 3JN
PERSHING NOMINEES LIMITED	42,594	THE ROYAL LIVER BUILDING	PIER HEAD	LIVERPOOL	L3 1LL
SECURITIES SERVICES NOMINEES LIMITED	40,800	10 HAREWOOD AVENUE	LONDON		NW1 6AA
WILLIAM JOSEPH EXCELL	40,327				
BEN TOMS	34,845				
WINTERFLOOD CLIENT NOMINEES LIMITED	32,996	THE ATRIUM BUILDING	CANNON BRIDGE HOUSE	25 DOWGATE HILL	EC4R 2GA
BEN HALL	32,289				
JAMES BREARLEY CREST NOMINEES LIMITED	30,935	PO BOX 34	WALPOLE HOUSE	UNIT 2	FY4 4WX
BREWIN NOMINEES LIMITED	29,230	PO BOX 1025	TIME CENTRAL	GALLOWGATE	NE99 1SX
KATHRYN BAILEY	28,098				
ABRAHAM KOZHIPATT	27,009				
THOMAS STENVOLL	27,009				
BHARTI SRIVASTAVA	25,746				
ROBERT GREEN	24,585				
CHARLOTTE BRAUND	23,739				
PRADUMNA WALIMBE	22,649				
SARRA LLOYD	22,443				
PLATFORM SECURITIES NOMINEES LTD	20,942	C/O F I S CORPORATE GOVERNANCE	THE WALBROOK BUILDING	25 WALBROOK	EC4N 8AF
BBHISL NOMINEES LIMITED	20,323	HSBC INSTITUTIONAL FUND SERVICES	HSBC BANK PLC	LEVEL 29	E14 5HQ
DOUGLAS LUBBOCK	19,966				
G&P CONSULTING LIMITED	18,234	2 MAGNOLIA DRIVE	WHITNASH	LEAMINGTON SPA	CV31 2SZ
DOMINIC GREENWOOD	17,422				
TRAVIS ADAMS	17,133				
MARK DUNKLEY	17,133				
STUART JONES	16,452				
BREWIN NOMINEES LIMITED	15,000	PO BOX 1025	TIME CENTRAL	GALLOWGATE	NE99 1SX
JAMES CAPEL (NOMINEES) LIMITED	12,300	HSBC BANK PLC	8 CANADA SQUARE	LONDON	E14 5HQ
JIM NOMINEES LIMITED	11,197	78 MOUNT EPHRAIM	TUNBRIDGE WELLS	KENT	TN4 8BS
HSDL NOMINEES LIMITED	10,927	TRINITY ROAD	HALIFAX		HX1 2RG
HUBWISE NOMINEES LIMITED	10,179	WAVERLEY COURT	WILTELL ROAD	LICHFIELD	WS14 9ET

Signature

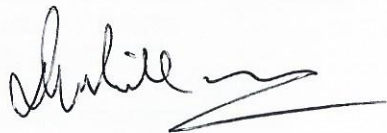

Date

25/4/24



EVANGELO SYRIGOS	9,733				
FRANTISEK SIMKU	8,546				
SECURITIES SERVICES NOMINEES LIMITED	7,652	10 HAREWOOD AVENUE	LONDON		NW1 6AA
NIGEL LEAPER	7,616				
ELIZABETH DE FREITAS	7,123				
DAVYCREST NOMINEES	7,000	DAVY HOUSE	49 DAWSON STREET	DUBLIN 2	
REDMAYNE (NOMINEES) LIMITED	6,650	9 BOND COURT	LEEDS		LS1 2JZ
HSDL NOMINEES LIMITED	6,067	TRINITY ROAD	HALIFAX		HX1 2RG
HSDL NOMINEES LIMITED	5,757	TRINITY ROAD	HALIFAX		HX1 2RG
FINECOBANK BANCA FINECO SPA	5,568	CITIGROUP CENTRE	CANADA SQUARE	CANARY WHARF	E14 5LB
RAVI BHAVSAR	5,424				
SMITH & WILLIAMSON NOMINEES LIMITED	5,000	206 ST VINCENT STREET	GLASGOW		G2 5SG
TRANSACT NOMINEES LIMITED	4,883	29 CLEMENT'S LANE	LONDON		EC4N 7AE
HSBC GLOBAL CUSTODY NOMINEE (UK) LIMITED	4,462	8 CANADA SQUARE	LONDON		E14 5HQ
CHASE NOMINEES LIMITED	4,403	PO BOX 7732	1 CHASESIDE	BOURNEMOUTH	BH1 9XA
ST ANNS SQUARE NOMINEES LIMITED	4,381	HENRY PILLING HOUSE	29 BOOTH STREET	MANCHESTER	M2 4AF
PIOTR SLOTWINSKI	4,168				
STEVE COX	3,476				
DANIEL MARTIN	3,195				
VIDACOS NOMINEES LIMITED	3,163	CITIGROUP CENTRE	CANADA SQUARE	CANARY WHARF	E14 5LB
ANNA MCLAUGHLIN	3,055				
LYNCHWOOD NOMINEES LIMITED	2,884	10 HAREWOOD AVENUE	LONDON		NW1 6AA
DARTINGTON PORTFOLIO NOMINEES LIMITED	2,825	TEMPLE POINT	REDCLIFFE WAY	BRISTOL	BS1 6NL
PERSHING NOMINEES LIMITED	2,812	THE ROYAL LIVER BUILDING	PIER HEAD	LIVERPOOL	L3 1LL
CHEVIOT CAPITAL (NOMINEES) LTD	2,800	SENATOR HOUSE	85 QUEEN VICTORIA STREE	LONDON	EC4V 4AB
ROCK (NOMINEES) LIMITED	2,795	55 BISHOPSGATE	LONDON		EC2N 3AS
PERSHING NOMINEES LIMITED	2,675	THE ROYAL LIVER BUILDING	PIER HEAD	LIVERPOOL	L3 1LL
HSBC GLOBAL CUSTODY NOMINEE (UK) LIMITED	2,500	8 CANADA SQUARE	LONDON		E14 5HQ
SECURITIES SERVICES NOMINEES LIMITED	2,500	10 HAREWOOD AVENUE	LONDON		NW1 6AA
VIDACOS NOMINEES LIMITED	2,209	CITIGROUP CENTRE	CANADA SQUARE	CANARY WHARF	E14 5LB

Signature

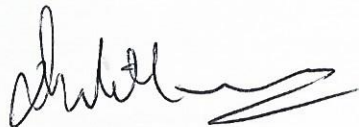

Date

25/4/24

MR COLIN LESLIE ROGERS	2,200				
GOLDMAN SACHS SECURITIES (NOMINEES) LIMITED	1,805	PLUMTREE COURT	25 SHOE LANE	LONDON	EC4A 4AU
LYNCHWOOD NOMINEES LIMITED	1,500	10 HAREWOOD AVENUE	LONDON		NW1 6AA
IDEALING NOMINEES LIMITED	1,383	FINSBURY HOUSE	23 FINSBURY CIRCUS	LONDON	EC2M 7EA
VIDACOS NOMINEES LIMITED	1,300	CITIGROUP CENTRE	CANADA SQUARE	CANARY WHARF	E14 5LB
WEALTH NOMINEES LIMITED	1,194	PO BOX 4976	LANCING		BN99 8WF
RAYMOND VAUGHAN GILES ESQ	1,000				
GOODBODY STOCKBROKERS NOMINEES LIMITED	1,000	ROYAL LIVER BUILDING	LIVERPOOL		L3 1LL
RCBIM NOMINEES LIMITED	1,000	1 THE SQUARE	TEMPLE QUAY	BRISTOL	BS1 6DG
GHC NOMINEES LIMITED	990	NORWICH HOUSE	22-30 HORSEFAIR STREET	LEICESTER	LE1 5BD
WEALTH NOMINEES LIMITED	986	PO BOX 4976	LANCING		BN99 8WF
INTERACTIVE BROKERS LLC	629	FLOOR 12	20 FENCHURCH STREET	LONDON	EC3M 3BY
SECURITIES SERVICES NOMINEES LIMITED	600	10 HAREWOOD AVENUE	LONDON		NW1 6AA
FERLIM NOMINEES LIMITED	400	100 OLD HALL STREET	LIVERPOOL		L3 9AB
VIDACOS NOMINEES LIMITED	300	CITIGROUP CENTRE	CANADA SQUARE	CANARY WHARF	E14 5LB
HSBC GLOBAL CUSTODY NOMINEE (UK) LIMITED	297	8 CANADA SQUARE	LONDON		E14 5HQ
VIDACOS NOMINEES LIMITED	190	CITIGROUP CENTRE	CANADA SQUARE	CANARY WHARF	E14 5LB
FUNSDIRECT NOMINEES LIMITED	182	TRIMBRIDGE HOUSE	TRIM STREET	BATH	BA1 1HB
MR MICHAEL JOHN GUERRIERIA	179				
MERRILL LYNCH INTERNATIONAL	90	FAO UK DIVIDENDS	2 KING EDWARD STREET	LONDON	EC1A 1HQ

145,142,723

Signature



Date

25/11/24

## Employees and Former Employees

**Note:** You must include details of all monies owed to employees and former employees in this schedule and disclose the total amount in the Company Creditors sheet, described simply as "employees and former employees"

Name of creditor or claimant	Address (with postcode)	Amount of debt £	Details of any security held by creditor	Date security given	Value of security £
Employees (preferential)		(49,727.87)	n/a	n/a	n/a
Employees (unsecured)		(493,413.86)	n/a	n/a	n/a

Signature

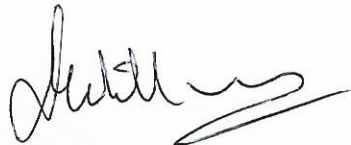

Date

25/4/24

## Statement of affairs

Name of Company Saietta Sunderland Plant Limited (in Administration)	Company number 08242130
In the High Court of Justice, Business and Properties Court, of England and Wales, Insolvency and Companies List (ChD)	Court case number CR 2024 001342

(a) Insert name and address of registered office of the Company

Statement as to the affairs of (a) Saietta Sunderland Plant Limited (in Administration) ("the Company")

c/o Ernst & Young LLP, The Paragon, Counterslip, Bristol, BS1 6BX

(b) Insert date

on the (b) 4 March 2024, the date that the Company entered Administration.

---

### Statement of Truth

I believe that the facts stated in this statement of affairs are a full, true and complete statement of the affairs of the above named Company as (b) 4 March 2024, the date that the company entered Administration.

Full name Anthony David Gott

Signed



Dated 25 April 2024

## A – Summary of Assets

Assets	Book Value (£)	Estimated to Realise (£)
Assets subject to fixed charge:	0	0
Assets subject to floating charge:		
Uncharged assets:		
Assets – Other		
Property, Plant and Equipment:		
Plant and Equipment	94,180.74	1.00
IT equipment	405.00	0.00
Intangible assets	0.00	0.00
Purchased software	1860.35	1.00
Inventory	504,164.67	1.00
Prepayments	9,788.33	0.00
Cash in bank	324,181.04	324,181.04
Estimated total assets available for preferential creditors	934,580.13	324,184.04

Signature



Date

25 April 2024

## A1 – Summary of Liabilities

		Estimated to realise (£)
<b>Estimated total assets available for preferential creditors (carried from page A)</b>	£	324,184.04
<b>Liabilities</b>	£	
Preferential creditors:-		
Primary preferential creditors	(15,751.47)	
Secondary preferential creditors	(9,925.60)	(25,677.07)
<b>Estimated deficiency/surplus as regards preferential creditors</b>	£	308,432.57
Estimated prescribed part of net property where applicable (to carry forward)	£0.00	0.00
<b>Estimated total assets available for floating charge holders</b>	£	308,432.57
Debts secured by floating charges	£0.00	0.00
<b>Estimated deficiency/surplus of assets after floating charges</b>	£	308,432.57
Estimated prescribed part of net property where applicable (brought down)	£0.00	0.00
<b>Total assets available to unsecured creditors</b>	£	308,432.57
Unsecured non-preferential claims (excluding any shortfall to floating charge holders)	£(3,206,135.53)	(3,206,135.53)
<b>Estimated deficiency/surplus as regards non-preferential creditors (excluding any shortfall to floating charge holders)</b>	£	<b>(2,897,702.96)</b>
Shortfall to floating charge holders (brought down)	£0.00	0.00
<b>Estimated deficiency/surplus as regards creditors</b>	£	<b>(2,897,702.96)</b>
Issued and called up capital	£100.0	100.00
<b>Estimated total deficiency/surplus as regards members</b>	£	<b>(2,897,602.96)</b>

Signature



Date

25 April 2024

## COMPANY CREDITORS

**Note:** You must include all creditors and identify all creditors under hire-purchase, chattel leasing or conditional sale agreements *and* customers claiming amounts paid in advance of the supply of goods or services *and* creditors claiming retention of title over property in the company's possession. Claims by employees, former employees and consumers should be given as a single figure, with details provided on the respective schedules

Name of creditor or claimant	Address (with postcode)	Amount of debt £	Details of any security held by creditor	Date security given	Value of security £
RS Components Ltd	PO BOX 99 Corby Northampton, Northants NN17 9RS	£231.38	n/a	n/a	n/a
TWC Facilities Ltd	The Stables Grizzlefield office Felixkirk Road, Thirsk YO7 2ED	£805.53	n/a	n/a	n/a
Total Business Computers Ltd	Albany House, Albany Road East Gateshead Industrial Estate Gateshead, Tyne & Wear NE8 3DG	£550.11	n/a	n/a	n/a
Total Recycling Serv	Total Recycling Serv Darlington, DL1 4PZ Great Britain	£456.00	n/a	n/a	n/a
RABB-IT Ltd	Ground Floor Unit 4 The Scribbling House Leeds, West Yorkshire LS28 5QS	3,756.00	n/a	n/a	n/a
Thomas Owen & Sons LTD	Unit 16, Brough Park The Fossway , NE6 2YF	£75.02	n/a	n/a	n/a
Jagdev Engineering Solutions Pvt Ltd	Sitarpur, Derabassi Tehsil, SAS Nagar District Lalru, 140501 India	£6,762.95	n/a	n/a	n/a
Storage Equipment Safety Service LTD	South Nelson Road South Nelson Ind Est Cramlington, NE231EG	£612.00	n/a	n/a	n/a
SAIETTA GRP	211 Heyford Park, Camp Road Upper Heyford Bicester, OX25 5HE	£1,609.02	n/a	n/a	n/a
Industrial Dielectrics (IDI Composites)	Unit 1, Oldbury Park Popes Lane Oldbury , B694RG	£1,155.35	n/a	n/a	n/a
Trafalgar Cases	Stanhope Works, Primrose Hill Kings Langley , WD48HS	£3,446.40	n/a	n/a	n/a
ENL Limited	Unit 6-9 Victory Trading Estate Kiln Road Portsmouth, PO3 5LP	£2,227.07	n/a	n/a	n/a

SCAN GLOBAL LOGISTICS (UK) LTD	Unit 2A Skyway 14 Calder Way, Colnbrook, Slough, SL3 0BQ	£2,404.10	n/a	n/a	n/a
DP FASTENERS LIMITED	Unit 16H Follingsby Avenue Follingsby Park Industrial Estate Gateshead. NE10 8YF	£307.63	n/a	n/a	n/a
EASTERN SEALS (UK) LTD	UNIT 3 SOVEREIGN BUSINESS PARK JUBILEE INDUSTRIAL ESTATE ASHINGTON. NE63 8UG	£503.16	n/a	n/a	n/a
FESS GROUP	UNIT A1 THORNE ENTERPRISE PARK DONCASTER, DN8 4HU Great Britain	£1,598.39	n/a	n/a	n/a
CONSULT TECHNIQUES INDIA PRIVATE LTD	PLOT 136 PHASE II INDUSTRIA AREA SECTOR - 59 HARYANA. 121004	£814.00	n/a	n/a	n/a
SKF (U.K.) LTD	SUNDON PARK ROAD LUTON, LU3 3BL	£2,770.85	n/a	n/a	n/a
Wave Utilities	Salvus House, Aykley Heads, Durham DH1 5TS	£2,002.12	n/a	n/a	n/a
British gas	British Gas Business, PO Box 343, SHEFFIELD S98 1EF	£17,556.87	n/a	n/a	n/a
Intercompany: Saietta Group plc	Intercompany: Saietta Group plc	£2,771,654.12	n/a	n/a	n/a
Intercompany: Saietta Europe B.V. (e-Traction	Intercompany: Saietta Europe B.V. (e-Traction Europe B.V.)	£277,546.94	n/a	n/a	n/a
HMRC – secondary preferential liability		£9,925.60	n/a	n/a	n/a

Signature



Date. 25 April 2024



# COMPANY SHAREHOLDERS

Name of Shareholder	Address (with postcode)	No. of shares held	Nominal Value	Details of Shares held
Saietta Group Plc	c/o Ernst & Young LLP, The Paragon, Counterslip, Bristol, BS1 6BX	100	1	
TOTALS		100	100	

Signature



Date

25 April 2024



## Appendix C Joint Administrators' receipts and payments account for the period from 4 March to 25 April 2024 – SGP

SoA estimated to realise	Note	4 March 2024 to 25 April 2024	Cumulative totals
(£)		(£)	(£)
	<b>Floating charge receipts</b>		
1,665,000.00	Plant & Machinery	1,612,690.00	1,612,690.00
1.00	Stock	23,001.00	23,001.00
Nil	Business Records	1.00	1.00
Nil	Goodwill	1.00	1.00
Nil	IP	1.00	1.00
Nil	Motor Vehicles	1.00	1.00
850,000.00	IP Licenses	847,297.00	847,297.00
24,424.61	Debtors	63,056.36	63,056.36
823,414.15	Cash at DOA	856,182.98	856,182.98
Nil	Bank Interest	640.15	640.15
		<b>3,402,871.49</b>	<b>3,402,871.49</b>
	LTO fee	62,093.15	62,093.15
<b>3,362,839.76</b>	<b>Total receipts</b>	<b>3,464,964.64</b>	<b>3,464,964.64</b>
	<b>Floating charge payments</b>		
	Gross Wages	84,539.73	84,539.73
	Employers NIC	9,406.12	9,406.12
	Employers Pension	6,312.05	6,312.05
	Professional Fees	25.00	25.00
	Intellectual Property Costs	320.20	320.20
	Insurance	1,150.00	1,150.00
	IT Costs	3,384.19	3,384.19
	Sundry Expenses	62.80	62.80
	Bank charges	17.20	17.20
		<b>105,217.29</b>	<b>105,217.29</b>
	LTO Rent	59,020.96	59,020.96
	<b>Total payments</b>	<b>164,238.25</b>	<b>164,238.25</b>
	<b>Balances in hand</b>	<b>3,300,726.39</b>	<b>3,300,726.39</b>
	<b>Represented by:</b>		
	Floating charge account	3,313,734.59	3,313,734.59
	VAT receivable	13,067.26	13,067.26
	VAT payable	(12,418.63)	(12,418.63)
	Pending payments	(75.36)	(75.36)
	Intercompany accounts	(9.60)	(9.60)
	Pension pending payments	(13,571.87)	(13,571.87)

### Notes

1. Receipts and payments are stated net of VAT.
2. LTO fee covers the LTO rent payable under the Silverstone property.

## Appendix C Joint Administrators' receipts and payments account for the period from 4 March to 25 April 2024 - SSP

SoA estimated to realise	Note	4 March 2024 to 25 April 2024	Cumulative totals
(£)		(£)	(£)
	<b>Floating charge receipts</b>		
324,181.04	Cash at DOA	324,181.04	324,181.04
Nil	Business Records	1.00	1.00
Nil	Goodwill	1.00	1.00
1.00	Intellectual Property	1.00	1.00
Nil	Intellectual Property licenses	1.00	1.00
Nil	Motor Vehicles	1.00	1.00
1.00	Plant & Machinery	1.00	1.00
Nil	Sunderland Assets	1.00	1.00
1.00	Stock	1.00	1.00
Nil	Bank Interest	265.84	265.84
<b>324,184.04</b>	<b>Total receipts</b>	<b><u>324,454.88</u></b>	<b><u>324,454.88</u></b>
	<b>Floating charge payments</b>		
	Hire of Equipment	673.20	673.20
	Insurance	1,150.00	1,150.00
	<b>Total payments</b>	<b><u>1,823.20</u></b>	<b><u>1,823.20</u></b>
	<b>Balances in hand</b>	<b><u>322,631.68</u></b>	<b><u>322,631.68</u></b>
	<b>Represented by:</b>		
	Floating charge account	322,268.64	322,268.64
	VAT payable	(1.60)	(1.60)
	VAT receivable	364.64	364.64
		<b><u>322,631.68</u></b>	<b><u>322,631.68</u></b>

### Notes

- Receipts and payments are stated net of VAT.

## Appendix D Statement of pre-administration costs

### Statement of pre-administration costs (shown NET of VAT)

	SGP Time costs £	SGP Expenses £	SSP Time costs £	SSP Expenses £	Total £	Details
Joint Administrators' time costs & expenses – contingency planning phase	114,728.36	97.74	18,902.64	Nil	133,728.74	Detailed in section 6 of the Proposals
Joint Administrators' time costs & expenses - pre-appt sale process phase	129,155.00	309.67	Nil	Nil	129,464.67	Detailed in section 6 of the Proposals
Legal Fees and Expenses	20,560.00	200.00	Nil	Nil	20,760.00	Detailed in section 6 of the Proposals
<b>Total costs incurred</b>	<b>264,443.36</b>	<b>607.41</b>	<b>18,902.64</b>	<b>Nil</b>	<b>283,953.41</b>	
<b>Paid before the administration</b>						
Joint Administrators' time costs – contingency planning	(16,000.00)	Nil	Nil	Nil	(16,000.00)	Paid by the Companies
Joint Administrators time costs pre-appt sale process	(40,000.00)	Nil	Nil	Nil	(40,000.00)	Paid by the Companies
<b>Unpaid pre-administration costs</b>	<b>208,443.36</b>	<b>607.41</b>	<b>18,902.64</b>	<b>Nil</b>	<b>227,953.41</b>	

Unpaid pre-administration costs are costs which had not been paid at the date of administration are still outstanding and are subject to approval under Rule 3.52 of the Insolvency (England and Wales) Rules 2016.

Unpaid pre-administration costs are not part of the proposals subject to approval under paragraph 53 of Schedule B1 of the Insolvency Act 1986. This means that they must be approved separately from the proposals. Further information on the way in which approval will be sought for unpaid pre-administration costs is set out in section 6 of this document

## Notice to creditors of deemed consent

### Paragraph 51 of Schedule B1 to the Insolvency Act 1986 and Rules 3.38, 15.7 and 15.8 of the Insolvency (England and Wales) Rules 2016

Name of Court	High Court of Justice, Business and Properties Court, of England and Wales, Insolvency and Companies List (ChD)
Case number	CR 2024 001342
Registered name of the Company	Saietta Sunderland Plant Limited (in Administration)
Other trading name(s) or style(s) of the Company	None
Another other registered name in the 12 months prior to Administration	None
Registered number:	08242130
Registered office address:	c/o Ernst & Young LLP The Paragon Counterslip Bristol BS1 6BX  Formerly: Fieldfisher LLP Riverbank House 2 Swan Lane London EC4R 3TT
Principal trading address (if different from above)	Mercantile Road Rainton Bridge Industrial Estate Houghton-le-Spring DH4 5PH
Date on which the company entered Administration:	4 March 2024
Date of appointment of Joint Administrators:	4 March 2024
<u>Details of the Joint Administrators</u>	
Lucy Winterborne Ernst & Young LLP The Paragon Counterslip Bristol BS1 6BX	Daniel Christopher Hurd Ernst & Young LLP 1 Colmore Square Birmingham B4 6HQ
Telephone number	SGPLCcomms@uk.ey.com
Name of alternative person to contact about the Administration	Ayse Hassan

NOTICE IS HEREBY GIVEN that the Joint Administrators of the above-named company are seeking approval of their proposals dated 26 April 2024 by deemed consent.

Creditors will be deemed to have consented to the approval of the proposals unless by the end of 13 May 2024 (**the decision date**) at least 10% in value of creditors who would be entitled to vote in a qualifying decision procedure have objected to approval and their objections have been made in accordance with the procedure set out below.

### **Objections**

Any creditor wishing to object to the proposed decision to approve our proposals – including any creditor who has opted out from receiving notices about the administration - must deliver to me, at the above address, a notice stating that the creditor so objects. The notice must be delivered to me at the above address not later than the end of **the decision date** together with a proof in respect of the creditor's claim which complies with the requirements of Rules 15.28 to 15.35 of the Insolvency (England and Wales) Rules 2016 failing which the objection will be disregarded.

Please note that creditors whose debts may be treated as small debts in accordance with Rule 14.31(1) of the Insolvency (England and Wales) Rules 2016 must still deliver a proof of claim if they wish to object.

It is my responsibility, as Joint Administrator convening the deemed consent procedure, to aggregate any objections to see if the threshold is met for the decision to be taken as not having been made.

If the threshold is met the deemed consent procedure will terminate without a decision being made on the proposals and if a decision is sought again on the same matter it will be sought by a decision procedure.

### **Requests for a physical meeting to be held**

Creditors who meet the thresholds in s.246ZE(7) of the Insolvency Act 1986, namely 10% in value of creditors, 10% in number of creditors or 10 creditors, may, within five business days from the date of delivery of this notice, make a request to me in writing for a physical meeting of creditors to be held to consider the approval of our proposals.

Signed

Daniel Christopher Hurd  
Joint Administrator

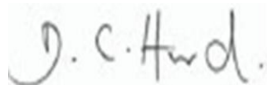

Date

26.04.2024



# Notice to creditors – invitation to form a creditors’ committee

## Rule 3.39, Insolvency (England and Wales) Rules 2016

Name of Court	High Court of Justice, Business and Properties Court, of England and Wales, Insolvency and Companies List (ChD)
Case number	CR 2024 001342
Registered name of the Company	Saietta Sunderland Plant Limited (in Administration)
Other trading name(s) or style(s) of the Company	None
Another other registered name in the 12 months prior to Administration	None
Registered number:	08242130
Registered office address:	c/o Ernst & Young LLP The Paragon Counterslip Bristol BS1 6BX  Formerly: Fieldfisher LLP Riverbank House 2 Swan Lane London EC4R 3TT
Principal trading address (if different from above)	Mercantile Road Rainton Bridge Industrial Estate Houghton-le-Spring DH4 3TT
Date on which the company entered Administration:	4 March 2024
Date of appointment of Joint Administrators:	4 March 2024
<u>Details of the Joint Administrators</u>	
Lucy Winterborne Ernst & Young LLP The Paragon Counterslip Bristol BS1 6BX	Daniel Christopher Hurd Ernst & Young LLP 1 Colmore Square Birmingham B4 6HQ
Telephone number	SGPLCcomms@uk.ey.com
Name of alternative person to contact about the Administration	Ayse Hassan

### **Invitation to form a creditors' committee**

Creditors are invited to decide whether a creditors' committee should be formed if sufficient creditors are willing to be members of the committee. Information on the role of committees can be found at <https://www.r3.org.uk/media/documents/publications/professional/R3-Guide-to-Creditors-Committees.pdf>

To be validly established, a committee must have at least three and not more than five members, who must have agreed to act.

Should you wish to form a committee, please follow the instructions in the nomination form attached to this notice and return the completed nomination form, with written agreements to act where appropriate, to me at the above address to arrive no later than 13 May 2024. Nominations can only be accepted if I am satisfied as to the creditor's eligibility under Rule 17.4 of the Insolvency (England and Wales) Rules 2016.

Signed

Daniel Christopher Hurd  
Joint Administrator

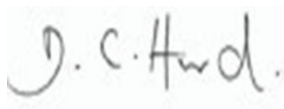
A handwritten signature in black ink that reads "D. C. Hurd." The signature is written in a cursive style and is positioned to the right of the typed name.

Date

26.04.2024

# Saietta Sunderland Plant Limited (in Administration)

## Nominations for creditors' committee

*You may nominate up to five creditors of the Company. Please note that before a person can act as a member of a creditors' committee that person must agree to do so.*

*In the event that more than five valid nominations are received, the five receiving the most votes will be appointed.*

*When you have completed this form, please return it with the creditor's written agreement to act (unless you are nominating yourself or your own organisation) to Lucy Winterborne at Ernst & Young LLP, The Paragon, Counterslip, Bristol, BS1 6BX to arrive no later than the closing date stated on the notice of invitation to form a committee.*

I nominate:

(Name of creditor) \_\_\_\_\_  
of

(Address) \_\_\_\_\_  
\_\_\_\_\_

(Name of creditor) \_\_\_\_\_  
of

(Address) \_\_\_\_\_  
\_\_\_\_\_

(Name of creditor) \_\_\_\_\_  
of

(Address) \_\_\_\_\_  
\_\_\_\_\_

(Name of creditor) \_\_\_\_\_  
of

(Address) \_\_\_\_\_  
\_\_\_\_\_

(Name of creditor) \_\_\_\_\_  
of

(Address) \_\_\_\_\_  
\_\_\_\_\_

to be appointed as (a) member(s) of the creditors' committee.

Signature \_\_\_\_\_

Name of signatory \_\_\_\_\_

On behalf of  
(name of creditor) \_\_\_\_\_

Date \_\_\_\_\_

The Insolvency Act 1986 and the Insolvency (England and Wales) Rules 2016

Administration Notice of Claim for Voting Purposes

**Saietta Sunderland Plant Limited (in Administration)**

Date of Administration: 4 March 2024

PLEASE NOTE: Once completed, this form will be used by the Joint Administrators ONLY for the purposes of voting in a creditors' decision procedure or a requisitioned meeting of creditors. The form will not constitute admission of the claim to rank for dividend in this or any subsequent procedure. For further information see Rules 15.28 to 15.35 of the Insolvency (England and Wales) Rules 2016.

Name of creditor

Address

Amount claimed, after deductions for payments made post-Administration or adjustments for set off (see notes overleaf)

Is the claim preferential or secured?

If secured, value of security

If you have made a retention of title claim against the company please attach details (see over)

Signature on behalf of creditor

Date

File with [SGPLCcomms@uk.ey.com](mailto:SGPLCcomms@uk.ey.com)

Reviewed by \_\_\_\_\_

## Notes to Administration Notice of Claim for Voting Purposes:

1. Please attach a detailed statement of your account as at the date on which the Company entered administration.

If you have claimed retention of title please provide details, including the value of any payments made, or goods returned, to you in respect of your claim.

If your claim is preferential (e.g. for wages, holiday pay or certain pension arrears) or secured please give details and attach supporting documentation.

VAT bad debt relief may usually be claimed six months after the date of supply.

## Extracts from the Insolvency (England and Wales) Rules 2016:

### 15.31 Calculation of voting rights

- (1) Votes are calculated according to the amount of each creditor's claim -
  - (a) in an Administration, as at the date on which the Company entered Administration, less -
    - (i) any payments that have been made to the creditor after that date in respect of the claim, and
    - (ii) any adjustment by way of set-off which has been made in accordance with rule 14.24 or would have been made if that rule were applied on the date on which the votes are counted; ...
- (4) Where a debt is wholly secured its value for voting purposes is nil.
- (5) Where a debt is partly secured its value for voting purposes is the value of the unsecured part.
- (6) However, the value of the debt for voting purposes is its full value without deduction of the value of the security in the following cases -
  - (a) where the Administrator has made a statement under paragraph 52(1)(b) of Schedule B1 and the administrator has been requested to seek a decision under paragraph 52(2); ...
- (7) No vote may be cast in respect of a claim more than once on any resolution put to the meeting; and for this purpose (where relevant), the claim of a creditor and of any member State liquidator in relation to the same debt are a single claim.
- (8) A vote cast in a decision procedure which is not a meeting may not be changed.
- (9) Paragraph (7) does not prevent a creditor or member State liquidator from -
  - (a) voting in respect of less than the full value of an entitlement to vote; or
  - (b) casting a vote one way in respect of part of the value of an entitlement and another way in respect of some or all of the balance of that value.

### 15.32 Calculation of voting rights: special cases

- (1) In an Administration, a creditor under a hire-purchase agreement is entitled to vote in respect of the amount of the debt due and payable by the Company on the date on which the Company entered Administration.
- (2) In calculating the amount of any debt for the purpose of paragraph (1), no account is to be taken of any amount attributable to the exercise of any right under the relevant agreement so far as the right has become exercisable solely by virtue of -
  - (a) the making of an Administration application;
  - (b) a notice of intention to appoint an Administrator or any matter arising as a consequence of the notice; or
  - (c) the Company entering Administration.